

Find Distribution Protection

Acti9

Miniature Circuit Breaker and Residual Current Protection Devices

2012



Schneider
Electric

www.fengshengelectric.com.sg

Contents

Principle of catalogue numbers ······	1
iID, iC60, iK60, Vigi iC60, Reflex iC60	
iC60 circuit breakers ······	2
Reflex iC60N ······	11
RCA remote controls ······	18
For iC60 circuit breakers	
Choice of earth leakage protection devices ······	23
Vigi iC60 add-on residual current devices ······	25
iID residual current circuit breakers ······	31
ARA automatic reclosers ······	37
For iC60 circuit breakers and iID residual current circuit breakers	
Residual current devices iDPN Vigi ······	42
Electrical auxiliaries ······	44
For iC60, iID, iSW-NA, RCA and ARA	
Accessories ······	48
For iC60, iID, iSW-NA, Reflex iC60, RCA and ARA	
iK60N circuit breakers ······	52
(curve C)	
iID K residual current circuit breakers ······	55
Multiclip 80 A splitter block ······	57
Earth leakage protection ······	59
Response time of medium-sensitivity residual current devices	
Tripping curves ······	63
Short-circuit current limiting ······	71

Description

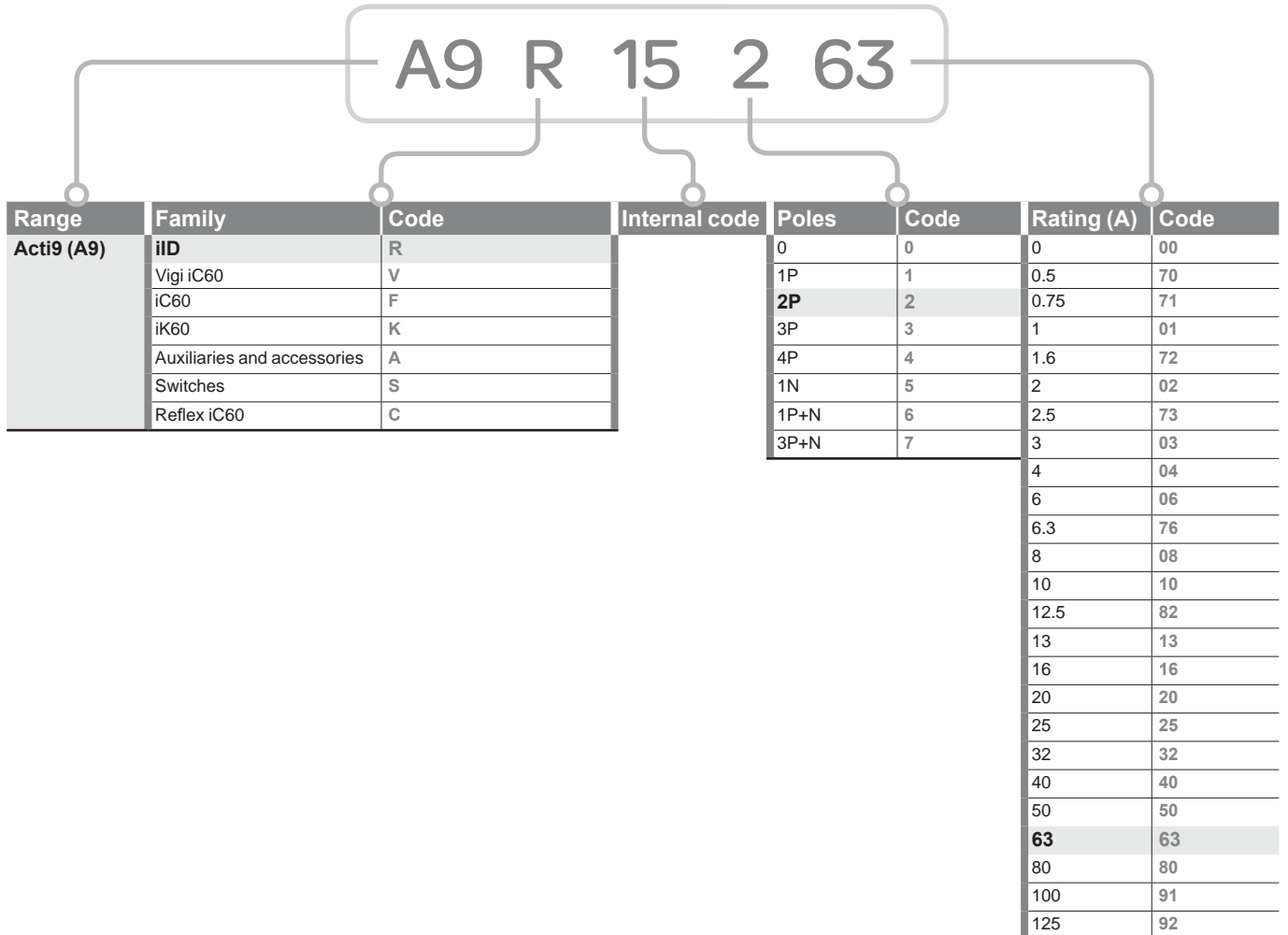

iC60N circuit breakers (curve B, C, D)

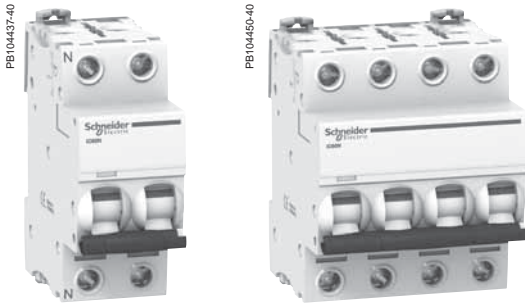

IEC/EN 60947-2 IEC/EN 60898-1

- iC60N circuit breakers are multi-standard circuit breakers which combine the following functions:
 - circuit protection against short-circuit currents,
 - circuit protection against overload currents,
 - suitable for industrial isolation according to IEC/EN 60947-2, standard.
 - fault tripping indication by a red mechanical indicator in circuit breaker front face.

Alternating current (AC) 50/60 Hz						
Breaking capacity (Icu) according to IEC/EN 60947-2						Service breaking capacity (Ics)
	Voltage (Ue)					
Ph/Ph (2P, 3P, 4P)	12 to 133 V	220 to 240 V	380 to 415 V	440 V		100 % of Icu
Ph/N (1P, 1P+N)	12 to 60 V	100 to 133 V	220 to 240 V	-		
Rating (In)	0.5 to 4 A	50 kA	50 kA	50 kA	25 kA	100 % of Icu
	6 to 63 A	36 kA	20 kA	10 kA	6 kA	75 % of Icu
Breaking capacity (Icn) according to IEC/EN 60898-1						
	Voltage (Ue)					
Ph/Ph	400 V					
Ph/N	230 V					
Rating (In)	0.5 to 63 A					6000 A

Direct current (DC)						
Breaking capacity (Icu) according to IEC/EN 60947-2						Service breaking capacity (Ics)
	Voltage (Ue)					
Between +/-	12 to 48 V	72 V	100 to 133 V		220 to 250 V	100 % of Icu
Number of poles	1P		2P (in series)	3P (in series)	4P (in series)	
Rating (In)	1 to 63 A	15 kA	6 kA	6 kA	15 kA	6 kA

Catalogue numbers

iC60N circuit breaker

Type	1P			2P		
Rating (In)	Curve					
	B	C	D	B	C	D
1 A	A9F73101	A9F74101	A9F75101	A9F73201	A9F74201	A9F75201
2 A	A9F73102	A9F74102	A9F75102	A9F73202	A9F74202	A9F75202
3 A	A9F73103	A9F74103	A9F75103	A9F73203	A9F74203	A9F75203
4 A	A9F73104	A9F74104	A9F75104	A9F73204	A9F74204	A9F75204
6 A	A9F73106	A9F74106	A9F75106	A9F73206	A9F74206	A9F75206
10 A	A9F73110	A9F74110	A9F75110	A9F73210	A9F74210	A9F75210
13 A	A9F73113	A9F74113	A9F75113	A9F73213	A9F74213	A9F75213
16 A	A9F73116	A9F74116	A9F75116	A9F73216	A9F74216	A9F75216
20 A	A9F73120	A9F74120	A9F75120	A9F73220	A9F74220	A9F75220
25 A	A9F73125	A9F74125	A9F75125	A9F73225	A9F74225	A9F75225
32 A	A9F73132	A9F74132	A9F75132	A9F73232	A9F74232	A9F75232
40 A	A9F73140	A9F74140	A9F75140	A9F73240	A9F74240	A9F75240
50 A	A9F73150	A9F74150	A9F75150	A9F73250	A9F74250	A9F75250
63 A	A9F73163	A9F74163	A9F75163	A9F73263	A9F74263	A9F75263
Width in 9-mm modules	2			4		

iC60N circuit breakers (curve B, C, D) (cont.)

PE104434-40

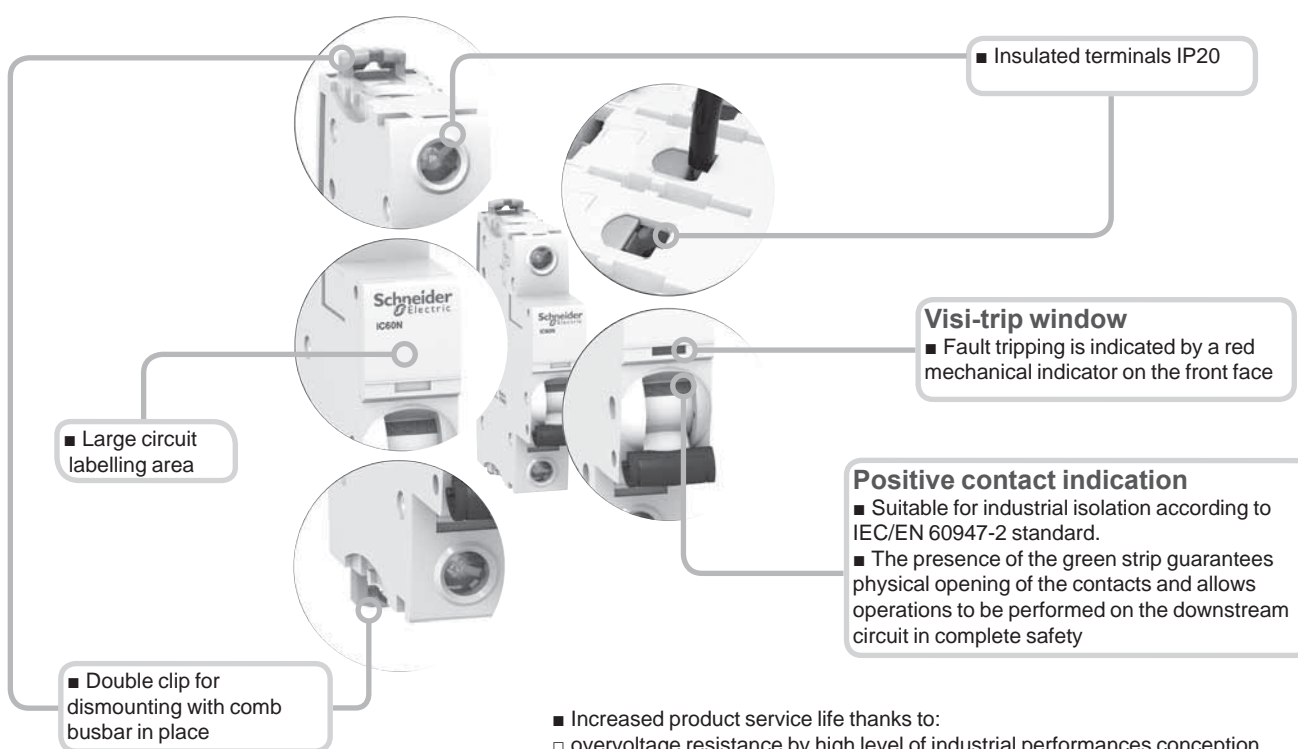

- Increased product service life thanks to:
 - overvoltage resistance by high level of industrial performances conception (pollution degree, rated impulse withstand voltage and insulation voltage),
 - high performance limitation (see limitation curves),
 - fast closing independent of the speed of actuation of the toggle.
- Remote indication, open/closed/tripped, by optional auxiliary contacts.
- Top or bottom electrical feeding.

3P			4P		
Curve			Curve		
B	C	D	B	C	D ⁽¹⁾
A9F73301	A9F74301	A9F75301	A9F73401	A9F74401	A9F75401
A9F73302	A9F74302	A9F75302	A9F73402	A9F74402	A9F75402
A9F73303	A9F74303	A9F75303	A9F73403	A9F74403	A9F75403
A9F73304	A9F74304	A9F75304	A9F73404	A9F74404	A9F75404
A9F73306	A9F74306	A9F75306	A9F76406	A9F77406	A9F75406
A9F73310	A9F74310	A9F75310	A9F76410	A9F77410	A9F75410
A9F73313	A9F74313	A9F75313	A9F73413	A9F74413	A9F75413
A9F73316	A9F74316	A9F75316	A9F76416	A9F77416	A9F75416
A9F73320	A9F74320	A9F75320	A9F76420	A9F77420	A9F75420
A9F73325	A9F74325	A9F75325	A9F76425	A9F77425	A9F75425
A9F73332	A9F74332	A9F75332	A9F76432	A9F77432	A9F75432
A9F73340	A9F74340	A9F75340	A9F76440	A9F77440	A9F75440
A9F73350	A9F74350	A9F75350	A9F76450	A9F77450	A9F75450
A9F73363	A9F74363	A9F75363	A9F76463	A9F77463	A9F75463
6			8		

iC60H circuit breakers (curve B, C, D)



Country approval pictograms

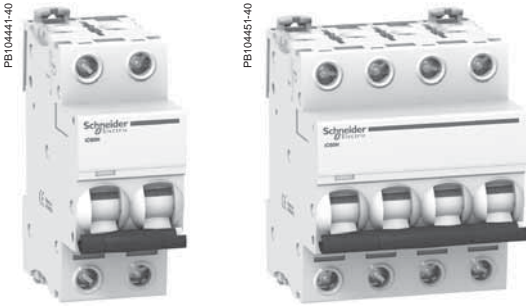

IEC/EN 60947-2 IEC/EN 60898-1

■ iC60H circuit breakers are multi-standard circuit breakers which combine the following functions:

- circuit protection against short-circuit currents,
- circuit protection against overload currents,
- suitable for industrial isolation according to IEC/EN 60947-2, standard.
- fault tripping indication by a red mechanical indicator in circuit breaker front face.

Alternating current (AC) 50/60 Hz

Breaking capacity (Icu) according to IEC/EN 60947-2

Ph/Ph (2P, 3P, 4P)	Voltage (Ue)				Service breaking capacity (Ics)	
	12 to 133 V	220 to 240 V	380 to 415 V	440 V		
Ph/N (1P, 1P+N)	12 to 60 V	100 to 133 V	220 to 240 V	-		
Rating (In)	0.5 to 4 A	70 kA	70 kA	70 kA	50 kA	100 % of Icu
	6 to 40 A	42 kA	30 kA	15 kA	10 kA	50 % of Icu
	50/63 A	42 kA	-	15 kA	10 kA	50 % of Icu

Breaking capacity (Icn) according to IEC/EN 60898-1

Ph/Ph	Voltage (Ue)	
	400 V	230 V
Ph/N	230 V	
Rating (In)	0.5 to 63 A	10000 A



Direct current (DC)

Breaking capacity (Icu) according to IEC/EN 60947-2

Between +/-	Voltage (Ue)				Service breaking capacity (Ics)	
	12 to 48 V	72 V	100 to 133 V	220 to 250 V		
Number of poles	1P		2P (in series)	3P (in series)	4P (in series)	
Rating (In)	1 to 63 A	20 kA	10 kA	10 kA	10 kA	100 % of Icu

Catalogue numbers

iC60H circuit breaker

Type	1P			2P		
						
Rating (In)	Curve			Curve		
	B	C	D	B	C	D
1 A	A9F83101	A9F84101	A9F85101	A9F83201	A9F84201	A9F85201
2 A	A9F83102	A9F84102	A9F85102	A9F83202	A9F84202	A9F85202
3 A	A9F83103	A9F84103	A9F85103	A9F83203	A9F84203	A9F85203
4 A	A9F83104	A9F84104	A9F85104	A9F83204	A9F84204	A9F85204
6 A	A9F83106	A9F84106	A9F85106	A9F83206	A9F84206	A9F85206
10 A	A9F83110	A9F84110	A9F85110	A9F83210	A9F84210	A9F85210
13 A	A9F83113	A9F84113	A9F85113	A9F83213	A9F84213	A9F85213
16 A	A9F83116	A9F84116	A9F85116	A9F83216	A9F84216	A9F85216
20 A	A9F83120	A9F84120	A9F85120	A9F83220	A9F84220	A9F85220
25 A	A9F83125	A9F84125	A9F85125	A9F83225	A9F84225	A9F85225
32 A	A9F83132	A9F84132	A9F85132	A9F83232	A9F84232	A9F85232
40 A	A9F83140	A9F84140	A9F85140	A9F83240	A9F84240	A9F85240
50 A	A9F83150	A9F84150	A9F85150	A9F83250	A9F84250	A9F85250
63 A	A9F83163	A9F84163	A9F85163	A9F83263	A9F84263	A9F85263
Width in 9-mm modules	2			4		

iC60H circuit breakers (curve B, C, D) (cont.)

PE104435-40

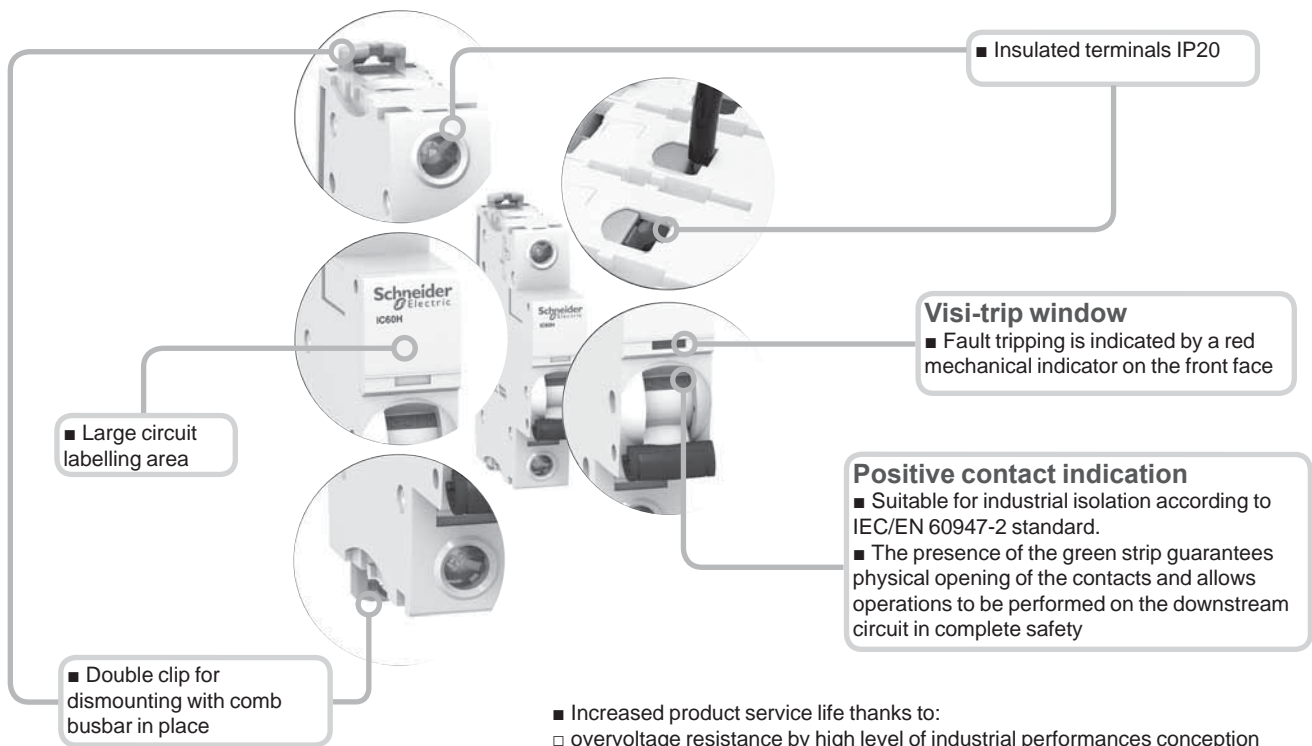

- Increased product service life thanks to:
 - overvoltage resistance by high level of industrial performances conception (pollution degree, rated impulse withstand voltage and insulation voltage),
 - high performance limitation (see limitation curves),
 - fast closing independent of the speed of actuation of the toggle.
- Remote indication, open/closed/tripped, by optional auxiliary contacts.
- Top or bottom electrical feeding.

3P			4P			
Curve			Curve			
B	C	D	B	C	K	Z
A9F83301	A9F84301	A9F85301	A9F93401	A9F94401	A9F95401	A9F92401
A9F83302	A9F84302	A9F85302	-	-	A9F95472	A9F92472
A9F83303	A9F84303	A9F85303	A9F93402	A9F94402	A9F95402	A9F92402
A9F83304	A9F84304	A9F85304	A9F93403	A9F94403	A9F95403	A9F92403
A9F83306	A9F84306	A9F85306	A9F93404	A9F94404	A9F95404	A9F92404
A9F83310	A9F84310	A9F85310	A9F93406	A9F94406	A9F95406	A9F92406
A9F83313	A9F84313	A9F85313	A9F93410	A9F94410	A9F95410	A9F92410
A9F83316	A9F84316	A9F85316	A9F93416	A9F94416	A9F95416	A9F92416
A9F83320	A9F84320	A9F85320	A9F93420	A9F94420	A9F95420	A9F92420
A9F83325	A9F84325	A9F85325	A9F93425	A9F94425	A9F95425	A9F92425
A9F83332	A9F84332	A9F85332	A9F93432	A9F94432	A9F95432	A9F92432
A9F83340	A9F84340	A9F85340	A9F93440	A9F94440	A9F95440	A9F92440
A9F83350	A9F84350	A9F85350	A9F93450	A9F94450	A9F95450	A9F92450
A9F83363	A9F84363	A9F85363	A9F93463	A9F94463	A9F95463	A9F92463

6

6

iC60L circuit breakers (curve B, C, K, Z)

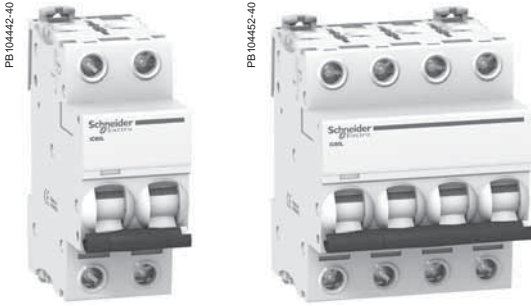

IEC/EN 60947-2 IEC/EN 60898-1 up to 40 A

- iC60L circuit breakers are multi-standard circuit breakers which combine the following functions:
 - circuit protection against short-circuit currents,
 - circuit protection against overload currents,
 - suitable for industrial isolation according to IEC/EN 60947-2, standard.
 - fault tripping indication by a red mechanical indicator in circuit breaker front face.



Alternating current (AC) 50/60 Hz						
Breaking capacity (Icu) according to IEC/EN 60947-2						Service breaking capacity (Ics)
Ph/Ph (2P, 3P, 4P)	Voltage (Ue)					
	12 to 133 V	220 to 240 V	380 to 415 V	440 V		100 % of Icu
Ph/N (1P)	12 to 60 V	100 to 133 V	220 to 240 V	-		
Rating (In)	0.5 to 4 A	100 kA	100 kA	100 kA	70 kA	100 % of Icu
	6 to 25 A	70 kA	-	25 kA	20 kA	50 % of Icu ⁽¹⁾
	32 / 40 A	70 kA	-	20 kA	15 kA	50 % of Icu
	50 / 63 A	70 kA	-	15 kA	10 kA	50 % of Icu

Breaking capacity (Icn) according to IEC/EN 60898-1	
Ph/Ph	Voltage (Ue)
	400 V
Ph/N	230 V
Rating (In)	0.5 to 40 A
	15000 A

Direct current (DC)						
Breaking capacity (Icu) according to IEC/EN 60947-2						Service breaking capacity (Ics)
Between +/-	Voltage (Ue)					
	12 to 48 V	72 V	100 to 144 V		220 to 250 V	100 % of Icu
Number of poles	1P		2P (in series)	3P (in series)	4P (in series)	
Rating (In)	1 to 63 A	25 kA	15 kA	15 kA	25 kA	15 kA

Catalogue numbers

iC60L circuit breaker

Type		1P				2P			
									
Rating (In)	Quality label ⁽²⁾	Curve							
		B	C	K	Z	B	C	K	Z
0.5 A		A9F93170	A9F94170	A9F95170	A9F92170	A9F93270	A9F94270	A9F95270	A9F92270
1 A		A9F93101	A9F94101	A9F95101	A9F92101	A9F93201	A9F94201	A9F95201	A9F92201
2 A		A9F93102	A9F94102	A9F95102	A9F92102	A9F93202	A9F94202	A9F95202	A9F92202
3 A		A9F93103	A9F94103	A9F95103	A9F92103	A9F93203	A9F94203	A9F95203	A9F92203
4 A		A9F93104	A9F94104	A9F95104	A9F92104	A9F93204	A9F94204	A9F95204	A9F92204
6 A		A9F93106	A9F94106	A9F95106	A9F92106	A9F93206	A9F94206	A9F95206	A9F92206
10 A		A9F93110	A9F94110	A9F95110	A9F92110	A9F93210	A9F94210	A9F95210	A9F92210
16 A		A9F93116	A9F94116	A9F95116	A9F92116	A9F93216	A9F94216	A9F95216	A9F92216
20 A		A9F93120	A9F94120	A9F95120	A9F92120	A9F93220	A9F94220	A9F95220	A9F92220
25 A		A9F93125	A9F94125	A9F95125	A9F92125	A9F93225	A9F94225	A9F95225	A9F92225
32 A		A9F93132	A9F94132	A9F95132	A9F92132	A9F93232	A9F94232	A9F95232	A9F92232
40 A		A9F93140	A9F94140	A9F95140	A9F92140	A9F93240	A9F94240	A9F95240	A9F92240
50 A		A9F93150	A9F94150	A9F95150 ⁽³⁾	A9F92150	A9F93250	A9F94250	A9F95250	A9F92250
63 A		A9F93163	A9F94163	A9F95163 ⁽³⁾	A9F92163	A9F93263	A9F94263	A9F95263	A9F92263
Width in 9-mm modules		2				4			

(1) 100 % of Icu for ratings 6 to 25 A under Ue 100 to 133 V AC Ph/Ph and Ue 12 to 60 V AC Ph/N.

(2) Information to be provided by the country.

(3) Without approval.

iC60L circuit breakers (curve B, C, K, Z) (cont.)

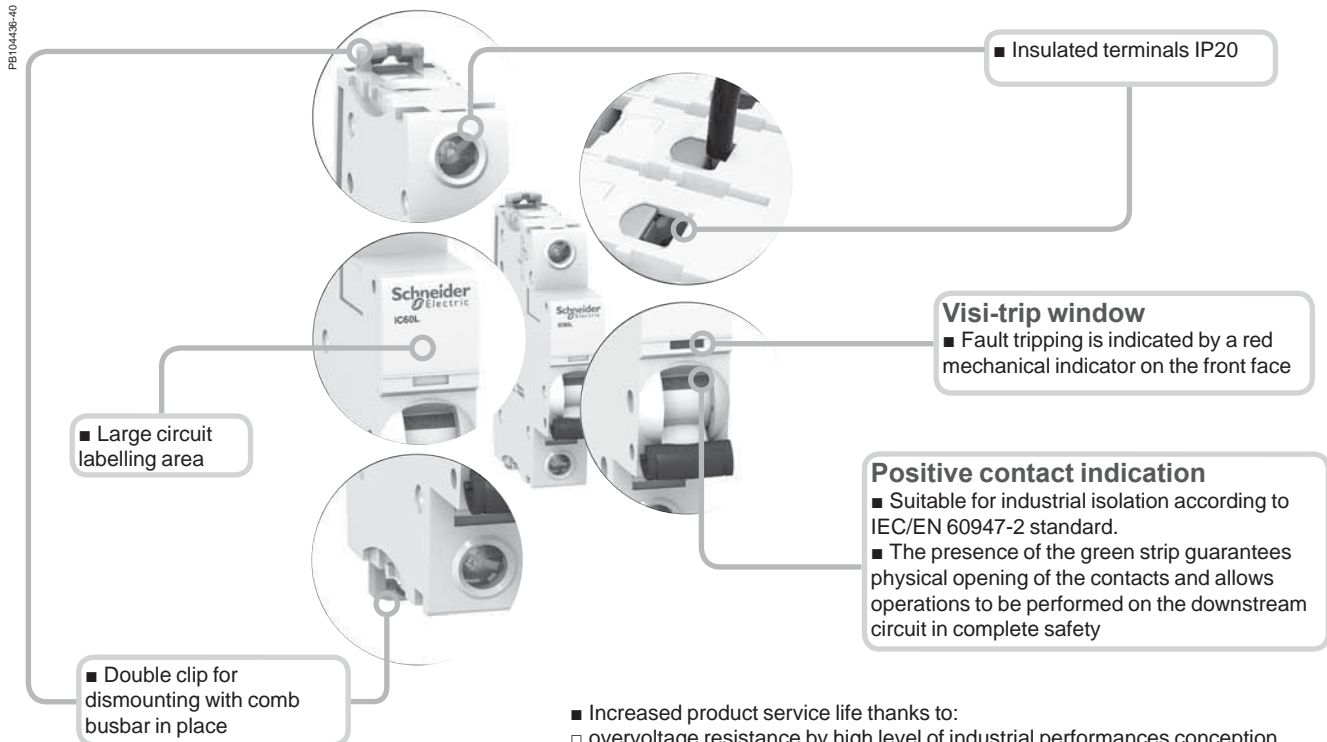

- Increased product service life thanks to:
 - overvoltage resistance by high level of industrial performances conception (pollution degree, rated impulse withstand voltage and insulation voltage),
 - high performance limitation (see limitation curves),
 - fast closing independent of the speed of actuation of the toggle.
- Remote indication, open/closed/tripped, by optional auxiliary contacts.
- Top or bottom electrical feeding.

3P				4P			
Curve				Curve			
B	C	K	Z	B	C	K	Z
A9F93370	A9F94370	A9F95370	A9F92370	A9F93470	A9F94470	A9F95470	A9F92470
A9F93301	A9F94301	A9F95301	A9F92301	A9F93401	A9F94401	A9F95401	A9F92401
A9F93302	A9F94302	A9F95302	A9F92302	A9F93402	A9F94402	A9F95402	A9F92402
A9F93303	A9F94303	A9F95303	A9F92303	A9F93403	A9F94403	A9F95403	A9F92403
A9F93304	A9F94304	A9F95304	A9F92304	A9F93404	A9F94404	A9F95404	A9F92404
A9F93306	A9F94306	A9F95306	A9F92306	A9F93406	A9F94406	A9F95406	A9F92406
A9F93310	A9F94310	A9F95310	A9F92310	A9F93410	A9F94410	A9F95410	A9F92410
A9F93316	A9F94316	A9F95316	A9F92316	A9F93416	A9F94416	A9F95416	A9F92416
A9F93320	A9F94320	A9F95320	A9F92320	A9F93420	A9F94420	A9F95420	A9F92420
A9F93325	A9F94325	A9F95325	A9F92325	A9F93425	A9F94425	A9F95425	A9F92425
A9F93332	A9F94332	A9F95332	A9F92332	A9F93432	A9F94432	A9F95432	A9F92432
A9F93340	A9F94340	A9F95340	A9F92340	A9F93440	A9F94440	A9F95440	A9F92440
A9F93350	A9F94350	A9F95350	A9F92350	A9F93450	A9F94450	A9F95450	A9F92450
A9F93363	A9F94363	A9F95363	A9F92363	A9F93463	A9F94463	A9F95463	A9F92463

4

6

iC60L circuit breakers instantaneous circuit breakers (ICB) (curve MA)

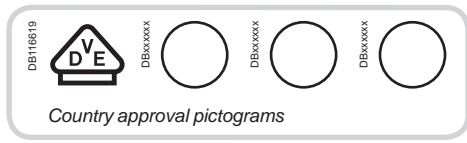

IEC/EN 60947-2

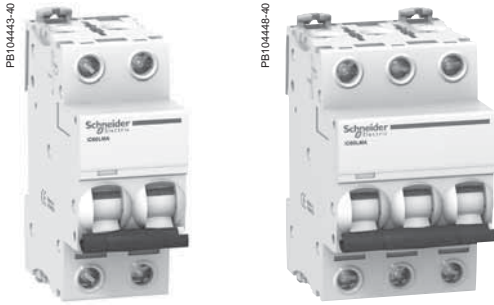

- iC60L curve MA circuit breakers combine the following functions:
 - circuit protection against short-circuit currents,
 - suitability for industrial isolation according to IEC/EN 60947-2, standard,
 - fault tripping indication by a red mechanical indicator in circuit breaker front face,
 - to be associated with overload protection for motor.

Alternating current (AC) 50/60 Hz				
Breaking capacity (Icu) according to IEC/EN 60947-2				Service breaking capacity (Ics)
Ph/Ph (2P, 3P)	Voltage (Ue)			
	220 to 240 V	380 to 415 V	440 V	
Rating (In)	1.6 to 16 A	40 kA	20 kA	15 kA
	25 à 40 A	30 kA	15 kA	10 kA
				50 % of Icu
				50 % of Icu

Catalogue numbers

iC60L instantaneous trip circuit breaker				
Type	2P		3P	
Rating (In)	Quality label ⁽¹⁾	Curve MA	Curve MA	
1.6 A		A9F90272	A9F90372	
2.5 A		A9F90273	A9F90373	
4 A		A9F90204	A9F90304	
6.3 A		A9F90276	A9F90376	
10 A		A9F90210	A9F90310	
12.5 A		A9F90282	A9F90382	
16 A		A9F90216	A9F90316	
25 A		A9F90225	A9F90325	
40 A		A9F90240	A9F90340	
Width in 9-mm modules		4	6	

(1) Information to be provided by the country.

Connection

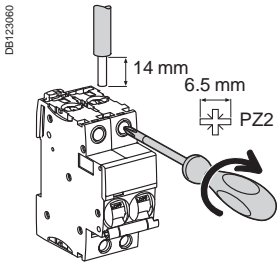

Rating	Tightening torque	Without accessory		With accessories			
		Copper cables Rigid	Flexible or ferrule	50 mm ² Al terminal	Screw-on connection for ring terminal	Multi-cables terminal Rigid cables	Flexible cables
0.5 to 25 A	2 N.m	DB122945 	DB122946 	DB122935 	DB119789 	DB119787 	
32 to 63 A	3.5 N.m	1 to 25 mm ²	1 to 16 mm ²	-	∅ 5 mm	-	-
		1 to 35 mm ²	1 to 25 mm ²	50 mm ²		3 x 16 mm ²	3 x 10 mm ²

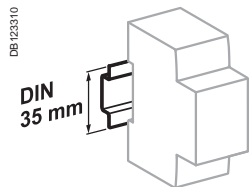

Clip on DIN rail 35 mm.

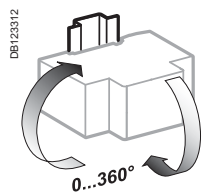

Indifferent position of installation.

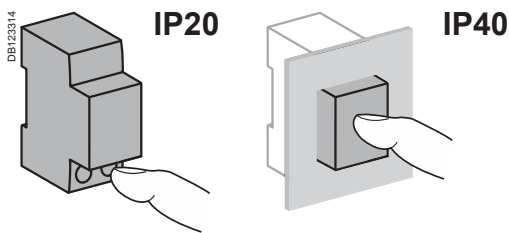

Technical data

Main characteristics		
According to IEC/EN 60947-2		
Insulation voltage (U _i)		500 V AC
Pollution degree		3
Rated impulse withstand voltage (U _{imp})		6 kV
Thermal tripping	Reference temperature	50 °C
	Temperature derating	See module CA908007
Magnetic tripping	B curve	4 I _n ± 20 %
	C curve	8 I _n ± 20 %
	D curve	12 I _n ± 20 %
Utilization category		A
According to IEC/EN 60898-1		
Limitation class		3
Rated making and breaking capacity of an individual pole (I _{cn1})		I _{cn1} = I _{cn}
Additional characteristics		
Breaking capacity under 1 pole with IT 380-415 V isolated neutral system (case of double fault)	40 A	4 kA
	50/63 A	3 kA
Degree of protection (IEC 60529)	Device only	IP20
	Device in modular enclosure	IP40 Insulation classe II
Endurance (O-C)	Electrical	10,000 cycles
	Mechanical	20,000 cycles
Overvoltage category (IEC 60364)		IV
Operating temperature		-35°C to +70°C
Storage temperature		-40°C to +85°C
Tropicalization (IEC 60068-1)		Treatment 2 (relative humidity 95 % to 55°C)

iC60 circuit breakers (cont.)

Weight (g)

Circuit-breaker	
Type	iC60N
1P	125
2P	250
3P	375
4P	500

Dimensions (mm)

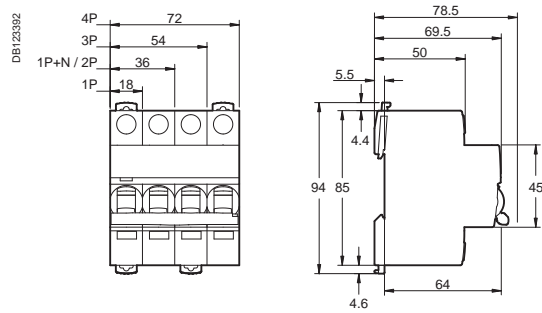

Control, remote control
Integrated control circuit
breakers

Reflex iC60N, iC60H (curves B, C, D)

PE106238-40

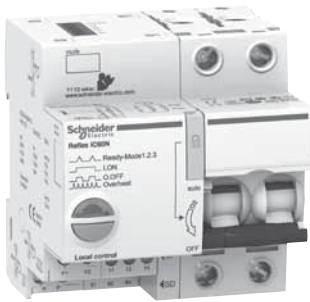

PE106238-40



IEC/EN 60947-2

The Reflex iC60 devices are integrated control circuit breakers which combine the following main functions in a single device:

- Remote control by latched and/or impulse-type order according to the 3 operating modes to be chosen by the user.
- Circuit breaker, to provide:
 - circuit protection against short-circuit currents,
 - circuit protection against overload currents,
 - disconnection in the industrial sector.

Resetting after a fault is performed manually, by the resetting handle.

The version with Ti24 allows direct interfacing of the Reflex iC60 with a PLC, to:

- Execute remote control (Y3).
- Indicate the state of the control circuit (OF) or circuit-breaker tripping (SD).

The iMDU auxiliary allows the Reflex iC60 to be controlled in 24/48 V AC/DC.

Alternating current (AC) 50 Hz				
Ultimate breaking capacity (Icu) as per IEC/EN 60947-2				Service breaking capacity (Ics)
Ph/Ph (2P, 3P, 4P)	Voltage (Ue)			
	220 to 240 V	380 to 415 V		
Reflex iC60N				
Rating (In)	10 to 40 A	20 kA	10 kA	75 % of Icu
	63 A	20 kA	10 kA	50 % of Icu
Reflex iC60H				
Rating (In)	10 to 40 A	30 kA	15 kA	50 % of Icu

Catalogue numbers

Reflex iC60 circuit breaker									
Type	2P			3P			4P		
	Curve			Curve			Curve		
Rating (In)	B	C	D	B	C	D	B	C	D
Reflex iC60N									
With Ti24 interface									
10 A	A9C61210	A9C62210	A9C63210	A9C61310	A9C62310	A9C63310	A9C61410	A9C62410	A9C63410
16 A	A9C61216	A9C62216	A9C63216	A9C61316	A9C62316	A9C63316	A9C61416	A9C62416	A9C63416
25 A	A9C61225	A9C62225	A9C63225	A9C61325	A9C62325	A9C63325	A9C61425	A9C62425	A9C63425
40 A	A9C61240	A9C62240	-	A9C61340	A9C62340	-	A9C61440	A9C62440	-
63 A	A9C61263	A9C62263	-	A9C61363	A9C62363	-	A9C61463	A9C62463	-
Without Ti24 interface									
10 A	-	A9C52210	-	-	A9C52310	-	-	A9C52410	-
16 A	-	A9C52216	-	-	A9C52316	-	-	A9C52416	-
25 A	-	A9C52225	-	-	A9C52325	-	-	A9C52425	-
40 A	-	A9C52240	-	-	A9C52340	-	-	A9C52440	-
63 A	-	A9C52263	-	-	A9C52363	-	-	A9C52463	-
Reflex iC60H									
With Ti24 interface									
10 A	A9C64210	A9C65210	A9C66210	A9C64310	A9C65310	A9C66310	A9C64410	A9C65410	A9C66410
16 A	A9C64216	A9C65216	A9C66216	A9C64316	A9C65316	A9C66316	A9C64416	A9C65416	A9C66416
25 A	A9C64225	A9C65225	A9C66225	A9C64325	A9C65325	A9C66325	A9C64425	A9C65425	A9C66425
40 A	A9C64240	A9C65240	-	A9C64340	A9C65340	-	A9C64440	A9C65440	-
Width in 9 mm modules	9			11			13		

Reflex iC60N, iC60H (curves B, C, D) (cont.)

PB 1 05980 70

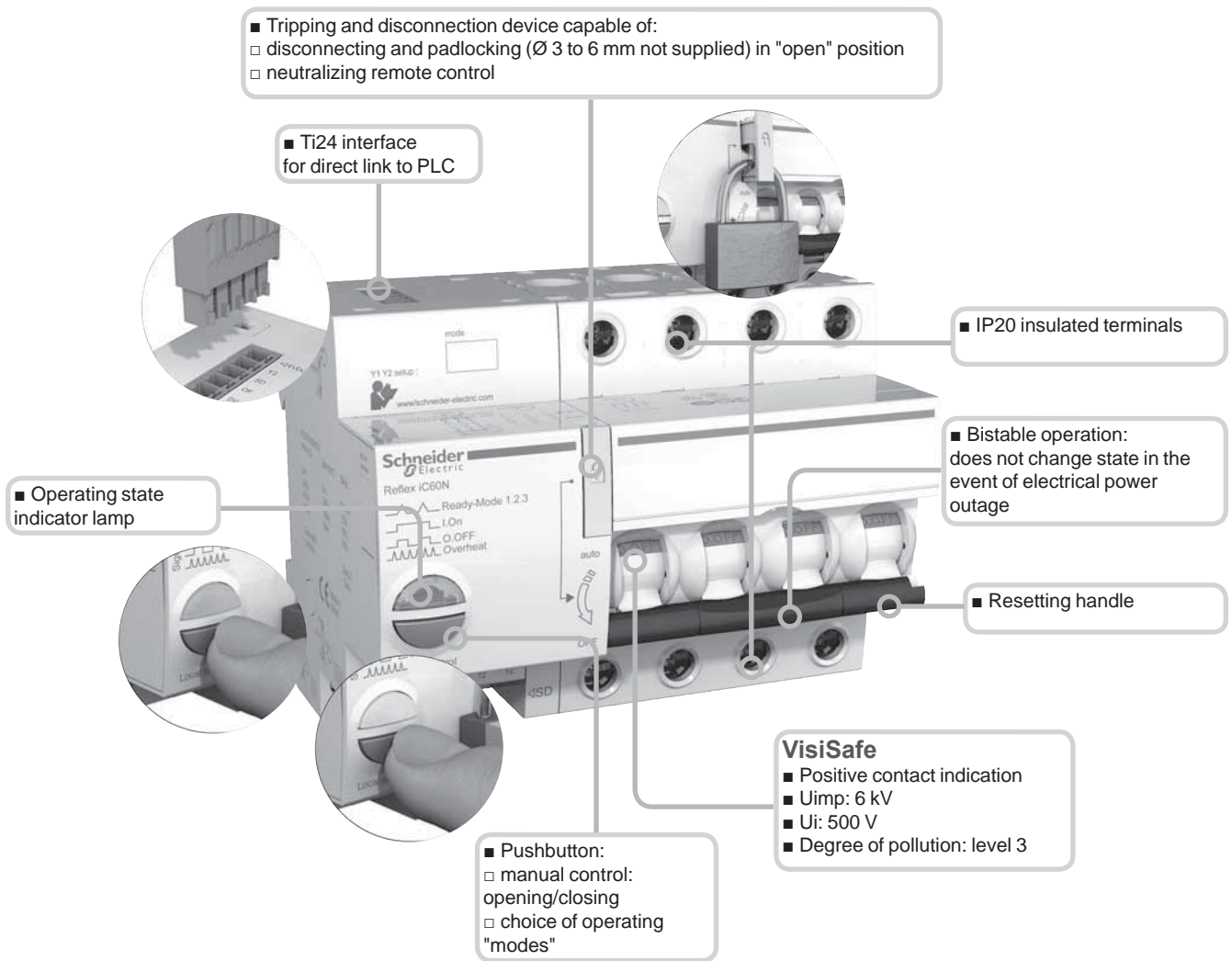

- Longer product service life thanks to:
 good overvoltage withstand capacity: products designed to provide a high industrial performance level (degree of pollution, rated impulse withstand voltage and insulation voltage),
 high limitation performances,
 fast closure independent of the speed of resetting of the operating handle.

DB123765

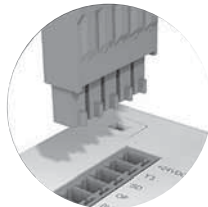

DB123516



Legend

Ti24 interface	
+24VDC	V DC power supply
Y3	Remote control by latched order
SD	Circuit-breaker tripping information
OF	Control circuit state information (open/closed)
0 V	V DC power supply
Y1	Latched order control
Y2	Control by impulse-type
N	230 V AC power supply
P	
OF	Control circuit state indication contact 11 12 14
SD	Circuit-breaker tripping indication contact 91 92 94

DB123517

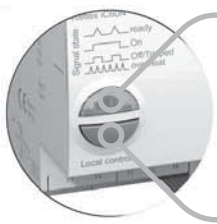

■ Operating state indicator lamp

■ Pushbutton for:
□ "mode" selection
□ opening/closing manual control

Remote control is possible by 3 operating modes to be set using the pushbutton on the front panel.

Three types of control: Y1, Y2, Y3

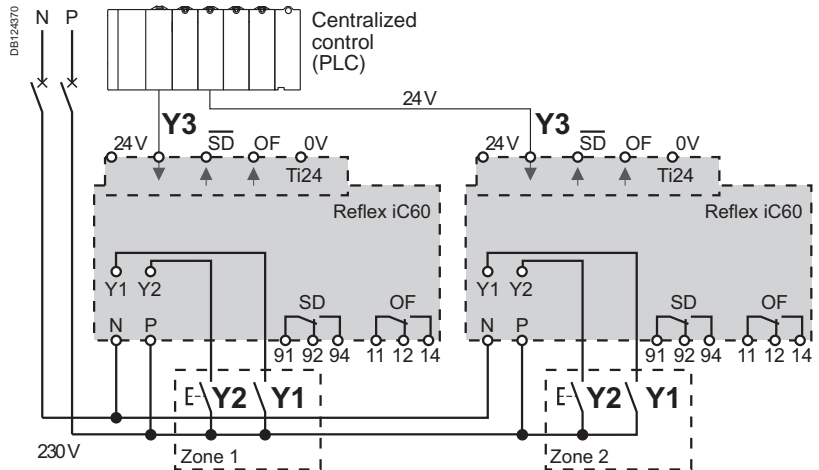

Operating modes

Mode 1: Reflex iC60 opening/closing, locally or centrally controlled

- The opening/closing orders come from various control points, and they are taken into account in their order of arrival
- Y1: latched order local control
- Y2: impulse-type local control
- Y3: latched order centralized control

Mode 2: Reflex iC60 opening/closing, possible inhibition of local impulse-type control

- Y1 is used to inhibit Y2
- Y1: local opening/Y2 inhibition latched order control
- Y2: impulse-type local opening/closing control
- Y3: latched order centralized opening/closing control

Mode 3: Reflex iC60 opening/closing, possible inhibition of centralised latched order control

- Y1 is used to inhibit Y3
- Y3 inhibition local latched order control
- Y2: impulse-type local opening/closing control
- Y3: latched order centralized opening/closing control

Reflex iC60 without Ti24 interface

DB124371

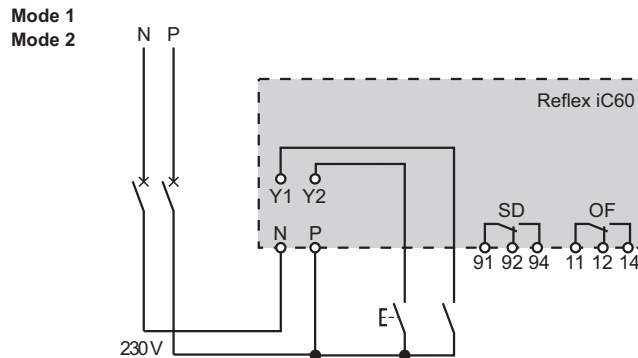

Reflex iC60 with Ti24 interface

DB124372

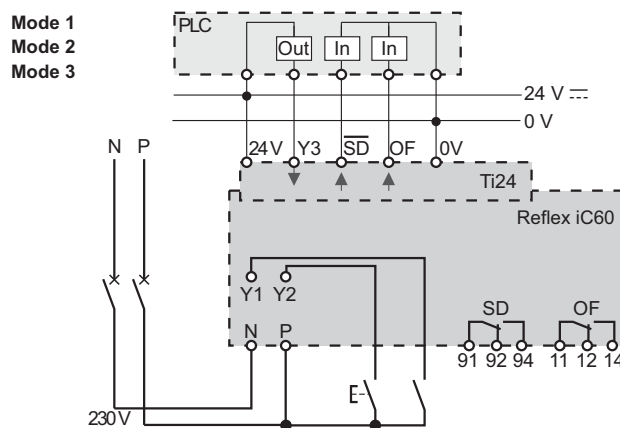
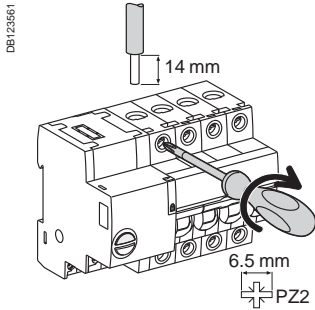

Table of modes

	Mode 1	Mode 2	Mode 3
Reflex iC60 without interface Ti24	■ Default mode	■ Possible mode	–
Reflex iC60 with interface Ti24	■ Possible mode	■ Possible mode	■ Default mode

Power connection



Terminal	Rating	Tightening torque	Without accessories		With accessories			
			Copper cables		Al terminal 50 mm ²	Screw-on connection for ring terminal	Multi-cable terminal	
			Rigid	Flexible or with ferrule			Rigid cables	Flexible cables
Power	10 to 25 A	2 N.m	DB122945 1 to 25 mm ²	DB122946 1 to 16 mm ²	DB11789 50 mm ²	DB11678 Ø 5 mm	DB11677 -	-
	40 to 63 A	3.5 N.m	1 to 35 mm ²	1 to 25 mm ²				

Control connection

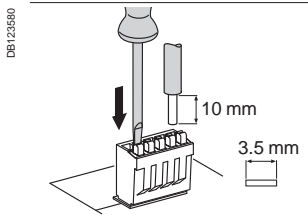
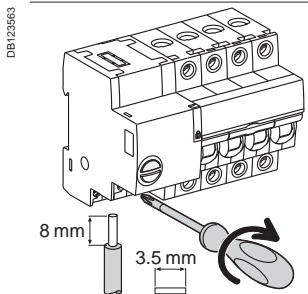
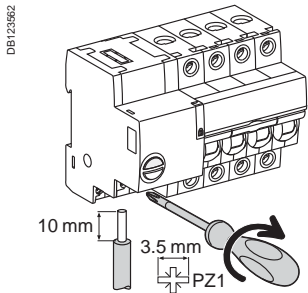

Terminal	Tightening torque	Without accessories		
		Copper cables		Flexible with ferrule
		Rigid	Flexible	
Power supply (N/P) Inputs (Y1/Y2)	1 N.m	DB122945 1 to 10 mm ²	DB123653 1 to 6 mm ²	DB123654 1 to 4 mm ²
Outputs (OF/SD)	0.7 N.m	1 to 2.5 mm ²	1 to 2.5 mm ²	1 to 1.5 mm ²
Ti24 interface	Spring-loaded terminals	0.5 to 1.5 mm ²	0.5 to 1.5 mm ²	0.5 to 1.5 mm ²

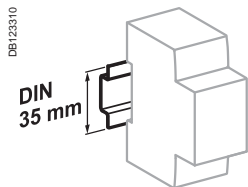

Clip on DIN rail 35 mm.

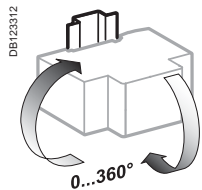

Indifferent position of installation.

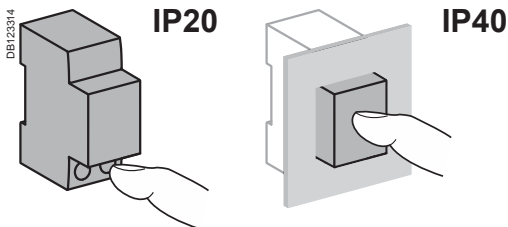

Technical data

Control circuit		
Supply voltage (Ue) (N/P)		230 V AC - 50 Hz
Control voltage (Uc)	Inputs (Y1/Y2)	230 V AC - 5 mA (24...48 V AC/DC, with iMDU auxiliary)
	Input (Y3)	24 V DC - 5.5 mA
Min. duration of control impulse (Y2)		≥ 250 ms
Response time (Y2)		≤ 200 ms
Consumption		≤ 1 W
Inrush consumption		< 1000 VA
Length of control wires	Inputs (Y1/Y2)	Cable: 100 m Wires in a sheath: 500 m
	Input (Y3)	500 m
Inrush current at 230 V - 50 Hz	2P	4.2 Å
	3P	8.2 Å
	4P	16.2 Å
Power circuit		
Max. working voltage (Ue)		400 V AC
Insulation voltage (Ui)		500 V
Rated impulse withstand voltage (Uimp)	Set to Disconnected	6 kV
	Set to Ready	4 kV
Thermal tripping	Reference temperature	50°C
Magnetic tripping	Curve B	4 In ± 20 %
	Curve C	8 In ± 20 %
	Curve D	12 In ± 20 %
Overvoltage category (IEC 60364)		IV
Temperature derating		See module CA908007
Indication / Remote control		
Potential-free changeover contact outputs (OF/SD)	Min.	24 V DC - 100 mA
	Max	230 V AC - 1 A
Ti24 interface (as per IEC 61131)		
Outputs (OF/SD)	Ti24 interface	24 V DC - 100 mA max
Endurance (O-C)		
Electrical	AC1 - AC7a	Up to 50,000 cycles ⁽¹⁾
	AC5a - AC5b	Up to 15,000 cycles ⁽¹⁾
	AC7c	Up to 20,000 cycles ⁽¹⁾
Mechanical		50,000 cycles
Additional characteristics		
Degree of protection (IEC 60529)	Device only	IP20
	Device in a modular enclosure	IP40 Insulation class II
Degree of pollution		3
Operating temperature		-25°C to +60°C
Storage temperature		-40°C to +85°C
Tropicalization		Treatment 2 (relative humidity of 93 % at 40°C)
Immunity to voltage dips		IEC 61000-4-11 class III
Immunity to power supply frequency variations		IEC 61000-4-28 and IACS E10
Immunity to harmonics		IEC 61000-4-13 class 2
Immunity to electrostatic discharges	Air	8 kV, IEC 61 000-4-2
	Contacts	4 kV, IEC 61 000-4-2
Immunity to stray magnetic fields		10 V/m up to 3 GHz, IEC 61000-4-3
Immunity to fast transients		4 kV from 5 to 100 kHz, IEC 61000-4-4
Immunity to shock waves		IEC 61000-4-5
Immunity to power frequency magnetic fields		10 V from 150 kHz to 80 MHz, IEC 61000-4-6
Immunité aux champs magnétiques à la fréquence du réseau		Level 4 30 A/m to IEC 61000-4-8 and IEC 61000-4-9
Conducted emissions		CISPR 11/22
Radiated emissions		CISPR 11/22

(1) See the derating table according to the load types and ratings

Reflex iC60N, iC60H (curves B, C, D) (cont.)

Weight (g)

Circuit breaker	
Type	Reflex iC60
2P	480
3P	620
4P	750

Dimensions (mm)

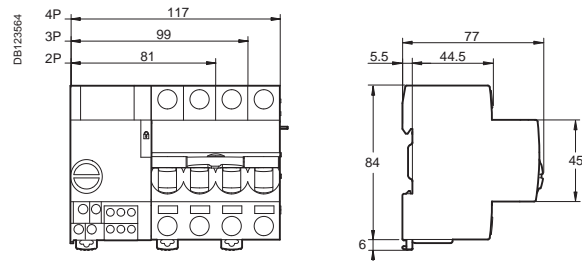

iMDU electrical auxiliary for Reflex iC60



A9C18195

The voltage matching module allows safety voltages of 24 and 48 V AC/DC to be used on the control inputs.

- Only connects to the Reflex iC60 circuit breakers remote controlled by a 220-240 V control voltage
- Galvanic isolation 6000 V
- Maximum combined power between terminals P and Y1/Y2: 100 mA at 230 V and 25°C.

Catalogue numbers

Electrical auxiliary for Reflex iC60

Type	Width in 9 mm modules
iMDU	A9C18195 1

Diagram

An iMDU electrical auxiliary allows up to a maximum of five Reflex iC60 to be controlled simultaneously at the same input.

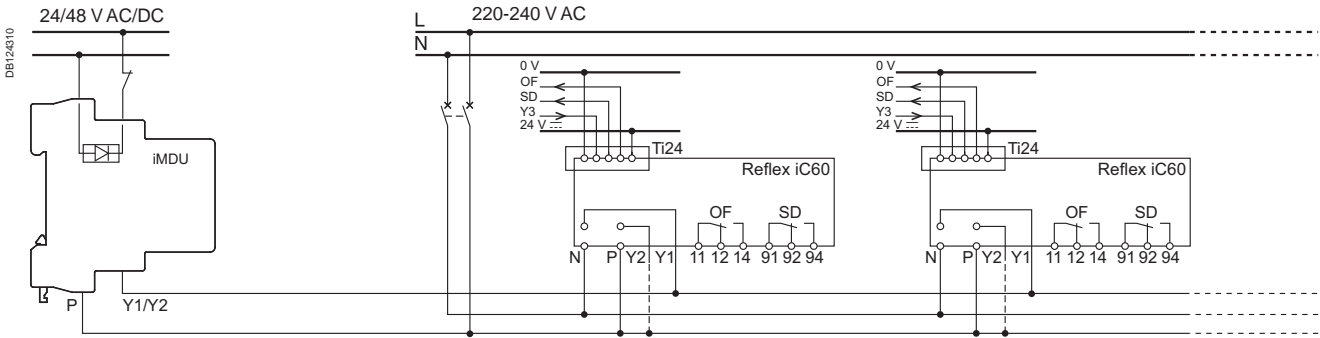

Dimensions (mm)

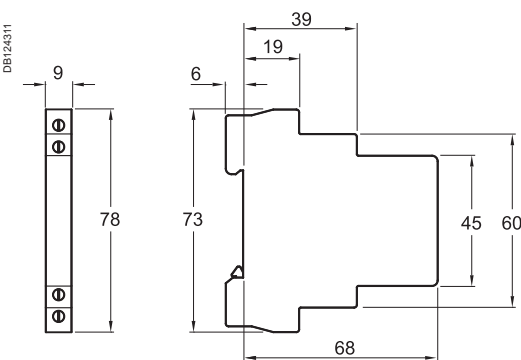

Connection

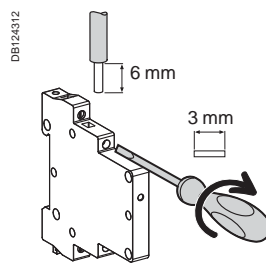

Type	Tightening torque	Copper cables	
		Rigid	Flexible or with ferrule
iMDU	1 N.m	1.5 mm ²	1.5 mm ²

Technical data

Main characteristics		
Control circuit voltage		24...48 V AC/DC
Insulation voltage (Ui)		500 V
Additional characteristics		
Degree of protection (IEC 60529)	Device only	IP20
	Device in modular enclosure	IP40 Insulation class II
Operating temperature		-20°C to +60°C
Storage temperature		-40°C to +80°C
Tropicalisation		Treatment 2 (relative humidity 95 % at 55°C)
Weight		53 g

RCA remote controls

For iC60 circuit breakers

PB100253-40



The RCA remote control system allows:

- Remote electrical control (opening and closing) of circuit breakers with or without Vigi add-on RCD, with or without auxiliary.
- Circuit-breaker resetting after tripping, in accordance with safety principles and the regulations in force.
- Local control by operating handle.
- Circuit placing in safety configuration by padlocking.

2 choices of operation after tripping:

- A: Enabling of remote circuit-breaker resetting;
- B: Inhibition of remote resetting.

The version with Ti24 interface allows:

- Direct interfacing of remote control with a programmable logic controller (PLC), a supervision system and any other communication device, having inputs/outputs in 24 V DC (control, OF and SD indications).
- Remote indication by "OF" potential-free contact.
- Provision of 2 operating modes, "1 and 3".

The iMDU auxiliary allows RCA control in 24/48 V AC/DC.

Catalogue numbers

RCA remote control			
Type			Width in 9 mm modules
For circuit breakers 1P, 1P+N, 2P	Voltage		
Without Ti24 interface	230 V AC, 50 Hz	A9C70112	7
With Ti24 interface	230 V AC, 50 Hz	A9C70122	7
For 3P, 4P circuit breakers			
Without Ti24 interface	230 V AC, 50 Hz	A9C70114	7
With Ti24 interface	230 V AC, 50 Hz	A9C70124	7

DB123813



Without Ti24 interface

DB123572



DB123573



With Ti24 interface

Legend	
Type	Application
OFF	All remote control inhibited
auto	
A	Circuit breaker remote reclosing after tripping allowed
B	Circuit breaker remote reclosing after tripping inhibited
Green indicator lamp	Remote control possible
Orange indicator lamp	Remote control impossible
1 (Ti24)	Mode 1
3 (Ti24)	Mode 3
Y1	Latched order local control
Y2	Impulse-type or latched order local control (depending on mode)
Y3	Latched order centralized control

Standard RCA

- The orders received on terminals Y1 and Y2 are taken into account progressively in their order of arrival.

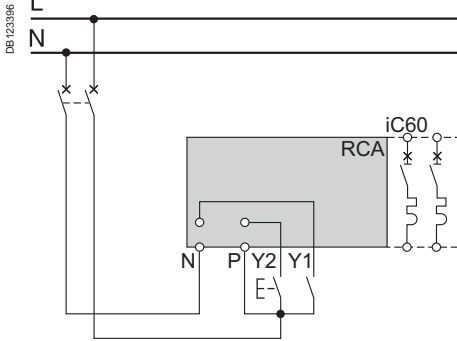

RCA Ti24

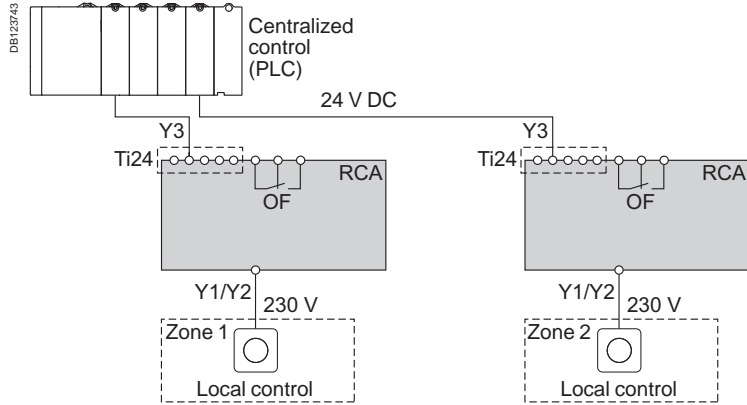

Mode 1: Locally or centrally controlled circuit-breaker opening/closing

- The orders come from various control points, and they are taken into account in their order of arrival
- Y1: Latched order local control
- Y2: Impulse-type local control
- Y3: Latched order centralized control

RCA Ti24 mode 1

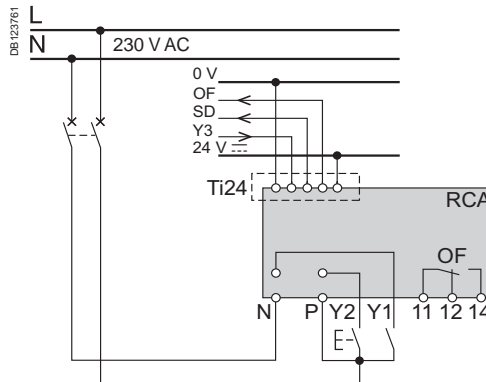

Mode 3: Centrally controlled opening/closing + local override

- 3 positions allowing a choice between override and centralized control:
- Y1: Latched order local control
- Y2: Latched order local control
- Y3: Latched order centralized control

RCA Ti24 mode 3

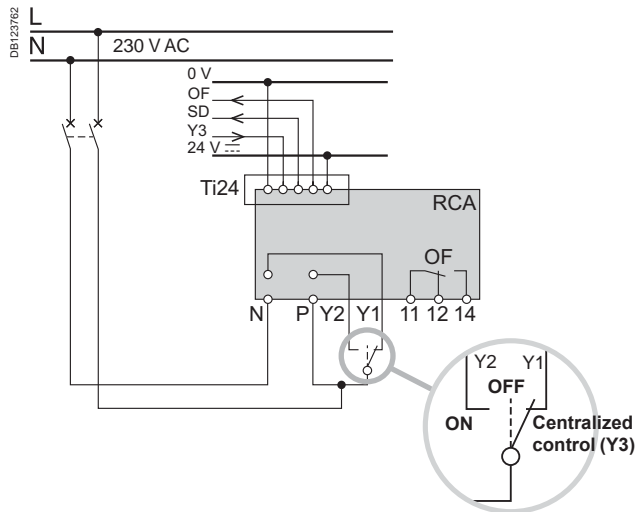

RCA remote controls (cont.)

For iC60 circuit breakers

DB123576

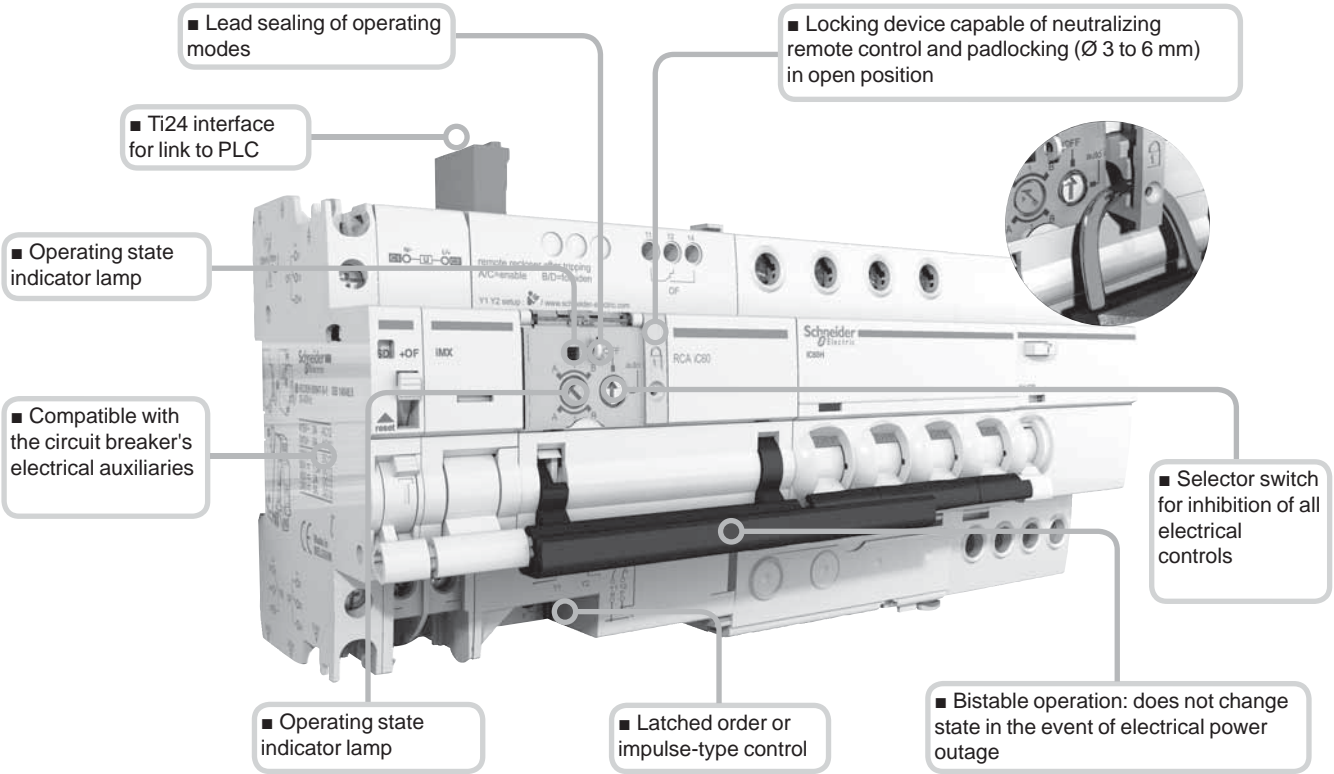

DB123763

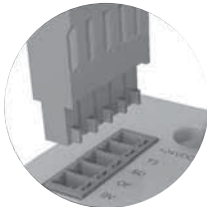

DB123578



DB123579

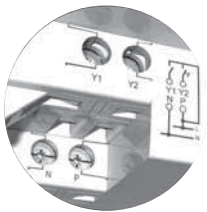

Legend	
Type	Application
+24VDC	V DC power supply
Y3	Latched order centralized control
SD	Circuit-breaker tripping information
OF	Control circuit state information (open/closed)
0 V	V DC power supply
Y1	Latched order local control
Y2	Impulse-type or latched order local control (depending on mode)
N	230 V AC, 50 Hz power supply
P	
OF	Circuit-breaker state indication contact (open/closed)



Indication auxiliaries	Tripping auxiliaries	RCA remote control	iC60 circuit breaker	Vigi iC60 add-on RCD
<p>3</p>	<p>2</p>	<p>1</p>	<p>PB108263-25</p>	<p>PB104437-25</p>
No	1 (iSD or iOF or iOF/SD+OF)	1 (iMX or iMN) max.		
1 iOF	1 (iSD or iOF or iOF/SD+OF)	No		

Connection

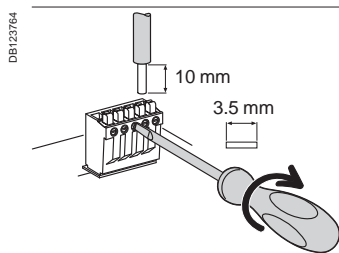
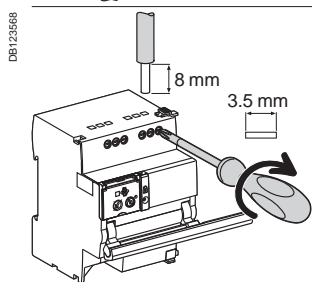
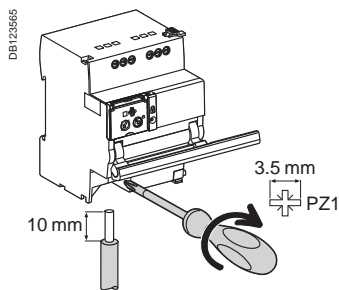

Terminal	Tightening torque	Without accessories		
		Copper cables		
		Rigid	Flexible	Flexible with ferrule
Power supply (N/P) Inputs (Y1/Y2)	1 N.m	0.5 to 10 mm ² 2 x 0.5 to 2 x 2.5 mm ²	0.5 to 6 mm ² 2 x 0.5 to 2 x 2.5 mm ²	0.5 to 4 mm ² 2 x 0.5 to 2 x 2.5 mm ²
Outputs (OF)	0.7 N.m	0.5 to 2.5 mm ² 2 x 0.5 to 2 x 1.5 mm ²	0.5 to 2.5 mm ² 2 x 0.5 to 2 x 1.5 mm ²	0.5 to 1.5 mm ² 2 x 0.5 to 2 x 1.5 mm ²
Ti24 interface	Spring-loaded terminals	0.5 to 1.5 mm ²	0.5 to 1.5 mm ²	-

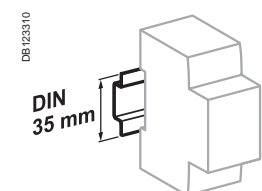

Clip on DIN rail 35 mm.

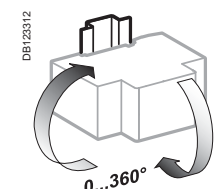

Indifferent position of installation.

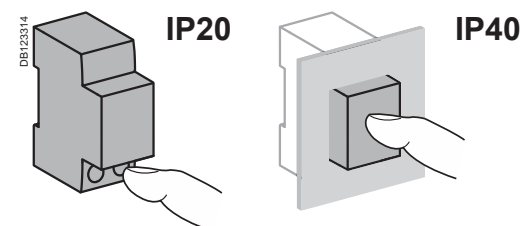

Technical data

Control circuit		
Supply voltage (Ue) (N/P)		230 V AC, 50 Hz
Control voltage (Uc)	Type 1 inputs (Y1/Y2)	230 V AC (as per IEC 61131-2)
Min. duration of control order (Y2)		≥ 200 ms
Response time (Y2)		< 500 ms
Consumption		≤ 1 W
Thermal self-protection with automatic Reset against overheating of the control circuit due to an abnormal number of operations		
Endurance (O-C) (RCA combined with a circuit breaker)		
Electrical/Mechanical		10,000 cycles
Indication / Remote control		
Potential free changeover contact output (OF)	Min.	24 V AC/DC, 10 mA
	Max.	230 V AC, 1 A
Input (Y1/Y2)	230 V AC	5 mA
Ti24 interface (as per IEC 61131)		
Type 1 input (Y3)	24 V DC	5.5 mA
Output (OF and SD)	24 V DC	In max.: 100 mA
Additional characteristics		
Degree of protection (IEC 60529)	Device only	IP20
	Device in a modular enclosure	IP40 Insulation class II
Insulation voltage (Ui)		400 V
Degree of pollution (IEC 60947)		3
Rated impulse withstand voltage (Uimp)		6 kV
Operating temperature		-25°C to +60°C
Storage temperature		-40°C to +70°C
Tropicalization		Treatment 2 (relative humidity of 93 % at +40°C)

RCA remote controls (cont.)

For iC60 circuit breakers

Weight (g)

Remote controls	
Type	RCA
For 1P, 1P+N, 2P circuit breakers	400
For 3P, 3P+N, 4P circuit breakers	430

Dimensions (mm)

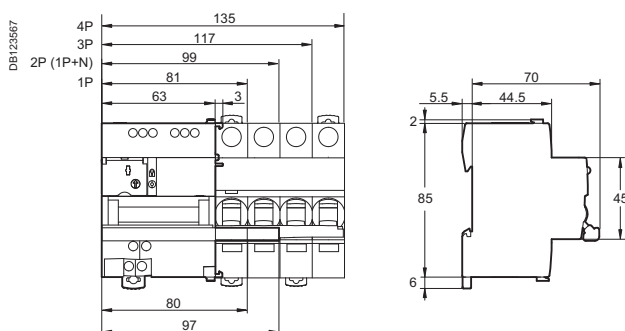



Choice of sensitivity

The sensitivity of an earth leakage protection device depends mainly on the function it has to perform:

- Protection from electric shock by direct contact.
- Protection from electric shock by indirect contact.
- Protection from fire due to current leakage.

The following table gives a reminder of:







- The circuits that must be protected against these various risks (obligation or recommendation).
- The type of earth leakage protection device to be used in each case, its sensitivity, and its location in the distribution diagram.

Type of protection	Obligations		Recommended by Schneider Electric	Sensitivity (I Δ n)		
	National standard <i>To be filled in according to the country standard</i>	International standard IEC 60364		30 mA (*)	100 mA to 3000 mA (depending on the earthing system)	300 mA (or 500 mA)
Protection from electric shock by direct contact 	<i>To be filled in according to the country standard</i>	Power supply for <ul style="list-style-type: none"> ■ General-purpose power sockets, up to 20 A ■ Appliances in the vicinity of a bathtub, shower, pond or swimming pool ■ Portable appliances for outdoor use, up to 32 A ■ Lighting for exhibition stands and shows ■ Outdoor lighting <i>To be modified according to national obligations (above)</i>	<ul style="list-style-type: none"> ■ Lighting in the home 	Setup in final distribution switchboard <ul style="list-style-type: none"> ■ Residual current device protecting a circuit ■ Residual current circuit breaker protecting a group of circuits 		
Protection from electric shock by indirect contact 	<i>To be filled in according to the country standard</i>	The entire power distribution system, except for devices: <ul style="list-style-type: none"> ■ With class II insulation ■ Operating at Safety Extra Low Voltage (class III) <i>To be modified according to national obligations (above)</i>	–		Setup in final distribution switchboard <ul style="list-style-type: none"> ■ Residual current circuit breaker or device, on incoming feeder Setup in subdistribution board or main switchboard <ul style="list-style-type: none"> ■ Residual current device protecting a circuit ■ Residual current device or circuit breaker protecting a group of circuits ■ On incoming feeder: residual current circuit breaker or device 	
Protection from fire due to current leakage 	<i>To be filled in according to the country standard</i>	<ul style="list-style-type: none"> ■ High-risk premises: <ul style="list-style-type: none"> □ explosion (BE3) □ fire (BE2) ■ Agricultural and horticultural buildings ■ Equipment for fairs, exhibitions and shows ■ Temporary outdoor recreational installations <i>To be modified according to national obligations (above)</i>	<ul style="list-style-type: none"> ■ Dilapidated buildings or electrical installations ■ Humid atmospheres: agricultural buildings, public swimming pools ■ Presence of chemical agents 		Setup in final distribution switchboard <ul style="list-style-type: none"> ■ Residual current circuit breaker or device, on incoming feeder Setup in subdistribution board or main switchboard <ul style="list-style-type: none"> ■ Residual current device protecting each circuit to a high-risk zone ■ Residual current device or circuit breaker protecting a group of circuits ■ On incoming feeder: residual current circuit breaker or device 	

(*) The 10 mA sensitivity is useful for certain very specific applications, where there is a risk that someone could sustain a non-dangerous current (10 to 30 mA) without being able to get free. Example: healthcare equipment for hospital beds. Generally, devices with this very high sensitivity are liable to cause frequent tripping, due to the natural leakage currents of the installation.

Interference immunity



Schneider Electric provides various equipment technologies capable of overcoming the consequences of interference of all kinds.

Operating conditions		Examples	Types				
			AC	A	A si	B	
Loads						   	
	With no special characteristics	<ul style="list-style-type: none"> General-purpose power sockets Incandescent lighting Household appliances: microwave oven, dishwasher, clothes dryer Electric heating, water heater 	■	■	■	■	
	Including a rectifier	Single phase	<ul style="list-style-type: none"> Household appliances: induction cooking appliances, washing machines (variable speed) Single-phase variable speed drives 	-	■	■	-
		Three phase	<ul style="list-style-type: none"> Three-phase variable speed industrial drives Three-phase uninterruptible power supplies 	-	-	-	■
	Generating high-frequency interference (current peaks, harmonics)		<ul style="list-style-type: none"> Fluorescent lighting powered by extra low voltage transformer, by electronic ballast Variable luminosity lighting Powerful IT equipment Single-phase variable speed industrial drives Air conditioning Telecommunications equipment Capacitor banks 	-	-	■	■
	Including an anti-harmonic filter in the power supply		<ul style="list-style-type: none"> Microcomputer systems Computer peripherals (printers, scanners, etc.) 	-	-	■	■
Electrical environment							
	Vicinity of equipment generating transient overvoltages	<ul style="list-style-type: none"> High-powered switching devices Reactive energy compensation banks 	-	-	■	■	
	Circuits powered by an uninterruptible power supply "Isolated neutral" (IT) earthing system	<ul style="list-style-type: none"> Backed-up networks 	-	-	■	■	
	Major risk of lightning strokes	<ul style="list-style-type: none"> Buildings protected by a lightning protection system Mountainous or humid regions Regions with high keraunic level 	-	-	■	■	
Atmosphere							
	Ambient temperature which could be less than -5°C		-	■	■	■	
	Presence of corrosive agents (AF2 to AF4) or dust	<ul style="list-style-type: none"> Indoor swimming pools Yacht harbours, marinas, camping grounds Water treatment Chemical industries, heavy industries, paper mills Mines and cellars, road tunnels Markets, stock raising, food processing industries 	-	-	■ (1)	-	

(1) SiE for C120 and NG125 circuit-breakers

Discrimination

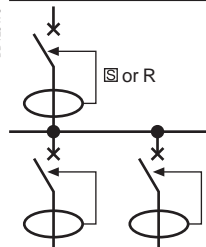
Residual current devices of average sensitivity (100 mA and more) are available in a selective (S) and delayed (R) version. This option ensures that, in the event of an earth fault downstream of the installation, only the defective part is switched off. The table below shows (in green) which upstream/downstream equipment combinations provide this discrimination.

Sensitivity (mA) - Downstream		Sensitivity (mA) - Upstream												
		Instantaneous						Selective S						Delayed R
		30	100	300	500	1000	3000	100	300	500	1000	3000	1000	3000
	Instantaneous	30	-	-	-	-	-	-	-	-	-	-	-	-
		100	-	-	-	-	-	-	-	-	-	-	-	-
		300	-	-	-	-	-	-	-	-	-	-	-	-
		500	-	-	-	-	-	-	-	-	-	-	-	-
		1000	-	-	-	-	-	-	-	-	-	-	-	-
		3000	-	-	-	-	-	-	-	-	-	-	-	-
	Selective S	100	-	-	-	-	-	-	-	-	-	-	-	
		300	-	-	-	-	-	-	-	-	-	-	-	
		500	-	-	-	-	-	-	-	-	-	-	-	
		1000	-	-	-	-	-	-	-	-	-	-	-	
		3000	-	-	-	-	-	-	-	-	-	-	-	
	Delayed R	1000	-	-	-	-	-	-	-	-	-	-	-	
		3000	-	-	-	-	-	-	-	-	-	-	-	

Vigi iC60 add-on residual current devices (AC type)

IEC/EN 61009-1

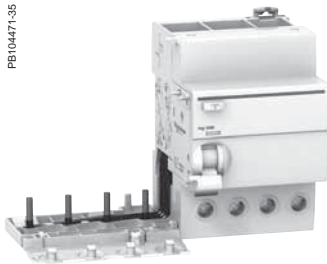
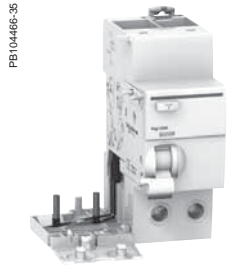

- Combined with iC60 circuit breaker, the Vigi iC60 provide:
 - protection of persons against electric shock by direct contact (≤ 30 mA),
 - protection of persons against electric shock by indirect contact (≥ 100 mA),
 - protection of installations against the risk of fire (300 mA or 500 mA).

Catalogue numbers

Vigi iC60 add-on residual current devices									
Type	AC								Width in 9 mm modules
Product	Vigi iC60								
Auxiliaries	Without auxiliaries								
2P 	Sensitivity	10 mA	30 mA	100 mA	300 mA	500 mA	300 mA	1000 mA	
	Rating	25 A	A9V41225 A9V01225*	A9V12225	A9V44225 A9V04225*	A9V16225	-	-	3
		40 A	-	A9V41240 A9V01240*	-	A9V44240 A9V04240*	A9V16240	-	4
		63 A	-	A9V41263 A9V01263*	A9V12263	A9V44263 A9V04263*	A9V16263	A9V15263	A9V19263
3P 	Sensitivity	10 mA	30 mA	100 mA	300 mA	500 mA	300 mA	1000 mA	
	Rating	25 A	-	A9V41325	-	A9V44325	A9V16325	-	6
		40 A	-	A9V41340	-	A9V44340	A9V16340	-	7
	63 A	-	A9V41363	-	A9V44363	A9V16363	A9V15363	A9V19363	7
4P 	Sensitivity	10 mA	30 mA	100 mA	300 mA	500 mA	300 mA	1000 mA	
	Rating	25 A	-	A9V41425	A9V12425	A9V44425	A9V16425	-	6
		40 A	-	A9V41440	-	A9V44440	A9V16440	-	7
	63 A	-	A9V41463	A9V12463	A9V44463	A9V16463	A9V15463	A9V19463	7
Voltage rating (Ue)	230 - 240 V, 400 - 415 V Except * 130 V								
Operating frequency	50/60 Hz								

Vigi iC60 add-on residual current devices (A type)

IEC/EN 61009-1

PB104466-35





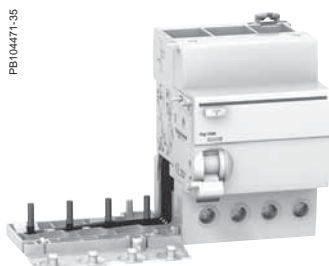



PB104471-35

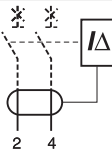

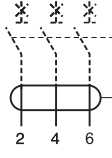
- Combined with iC60 circuit breaker, the Vigi iC60 provide:
 - protection of persons against electric shock by direct contact (30 mA),
 - protection of persons against electric shock by indirect contact (≥ 100 mA),
 - protection of installations against the risk of fire (300 mA or 500 mA).

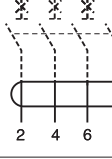
Catalogue numbers

Vigi iC60 add-on residual current devices										
Type	A 							Width in 9 mm modules		
Product	Vigi iC60									
Auxiliaries	Without auxiliaries									
2P 	Rating	Sensitivity	30 mA	100 mA	300 mA	500 mA	300 mA 	1000 mA 		
		25 A	A9V51225	A9V22225	A9V54225	A9V26225	-	-	3	
	63 A	A9V51263	A9V22263	A9V54263	A9V26263	A9V25263	A9V29263	4		
3P 	Rating	Sensitivity	30 mA	100 mA	300 mA	500 mA	300 mA 	1000 mA 		
		25 A	A9V51325	A9V22325	A9V54325	A9V26325	-	-	6	
	63 A	A9V51363	-	A9V54363	A9V26363	A9V25363	A9V29363	7		
4P 	Rating	Sensitivity	30 mA	100 mA	300 mA	500 mA	300 mA 	1000 mA 		
		25 A	A9V51425	A9V22425	A9V54425	A9V26425	-	-	6	
	63 A	A9V51463	A9V22463	A9V54463	A9V26463	A9V25463	A9V29463	7		
Voltage rating (Ue)			230 - 240 V, 400 - 415 V							
Operating frequency			50/60 Hz							

Vigi iC60 add-on residual current devices (Asi type)

PB104466-35



PB104471-35

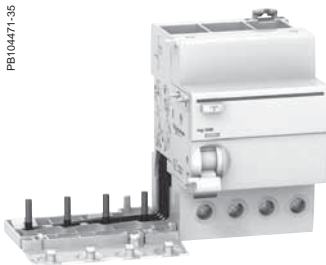





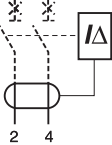

IEC/EN 61009-1

- Combined with iC60 circuit breaker, the Vigi iC60 provide:
 - protection of persons against electric shock by direct contact (≤ 30 mA),
 - protection of persons against electric shock by indirect contact (≥ 300 mA),
 - protection of installations against the risk of fire (300 mA).

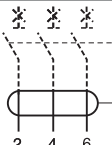
The Asi type provides increased immunity from electrical interference and polluted or corrosive environments.

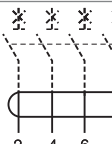
Catalogue numbers

Vigi iC60 add-on residual current devices							
Type	Asi 					Width in 9 mm modules	
Product	Vigi iC60						
Auxiliaries	Without auxiliaries						
2P 	Rating	Sensitivity	10 mA	30 mA	300 mA 	1000 mA 	
		25 A	A9V30225	A9V61225	-	-	3
		40 A	-	A9V61240	-	-	4
		63 A	-	A9V61263	A9V65263	A9V39263	4
3P 	Rating	Sensitivity	10 mA	30 mA	300 mA 	1000 mA 	
		25 A	-	A9V61325	-	-	6
		40 A	-	A9V61340	-	-	7
		63 A	-	A9V61363	A9V65363	A9V39363	7
4P 	Rating	Sensitivity	10 mA	30 mA	300 mA 	1000 mA 	
		25 A	-	A9V61425	-	-	6
		40 A	-	A9V61440	-	-	7
		63 A	-	A9V61463	A9V65463	A9V39463	7
Voltage rating (Ue)			230 - 240 V, 400 - 415 V				
Operating frequency			50/60 Hz				

Vigi iC60 add-on residual current devices (AC, A, Asi types)

Connection

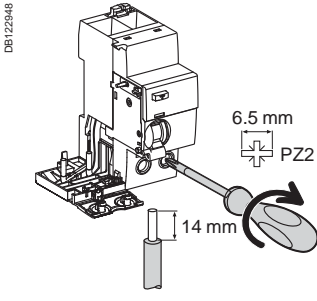

Type	Rating	Tightening torque	Copper cables	
			Rigid	Flexible or ferrule
Vigi iC60	25 A	2 N.m	1 to 25 mm ²	1 to 16 mm ²
	40 to 63 A	3.5 N.m	1 to 35 mm ²	1 to 25 mm ²

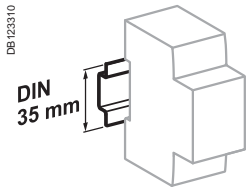

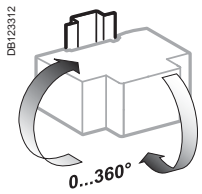

Clip on DIN rail 35 mm.

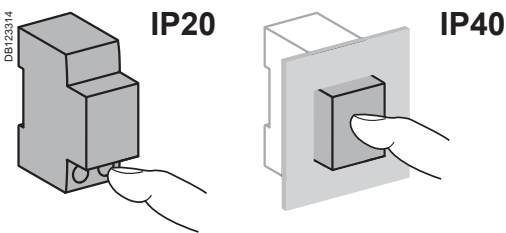

Indifferent position of installation.



Technical data

Main characteristics		
According to IEC 60947-2		
Insulation voltage (U _i)		500 V
Pollution degree		3
Rated impulse withstand voltage (U _{imp})		6 kV
According to IEC/EN 61009-1		
Surge current withstand (8/20 μs) without tripping	AC and A types (no selective )	250 Å
	AC, A types (selective )	3 kÅ
	Asi type	3 kÅ
Additional characteristics		
Degree of protection	Device only	IP20
	Device in modular enclosure	IP40
		Insulation classe II
Operating temperature	AC type	-5°C to +60°C
	A and Asi types	-25°C to +60°C
Storage temperature		-40°C to +85°C

Vigi iC60 add-on residual current devices (AC, A, Asi types) (cont.)

Weight (g)

Add-on residual current devices	
Type	Vigi iC60
2P	165
3P	210
4P	245

Dimensions (mm)

Vigi iC60 25 A

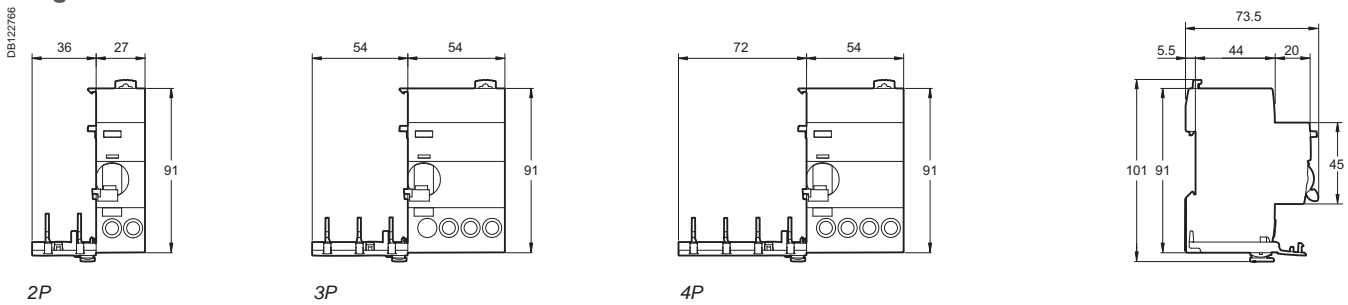

Vigi iC60 40 and 63 A

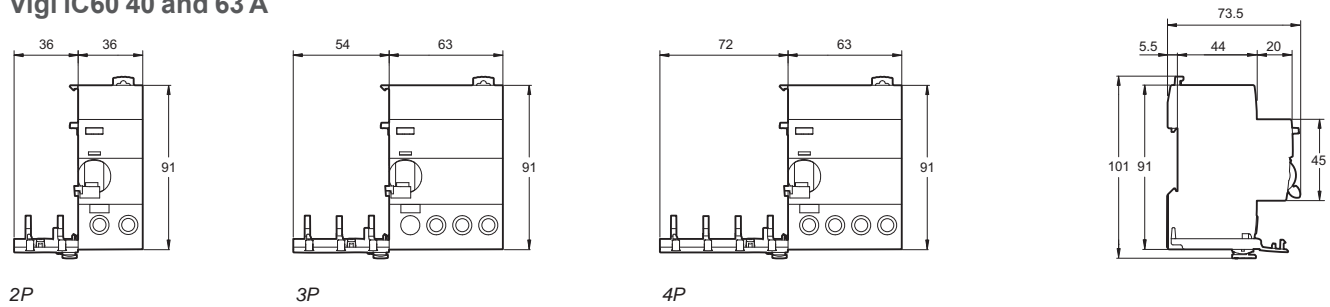

Vigi iC60 add-on residual current devices (AC, A, Asi types) (cont.)

PB104466-51

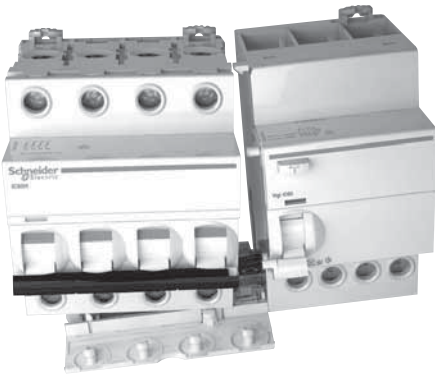

Association iC60a, N, H, L + Vigi iC60

iC60	Vigi iC60 25 A	Vigi iC60 40 A	Vigi iC60 63 A
0.5 A to 25 A	■	■	■
32 A - 40 A	NO	■	■
50 A - 63 A	NO	NO	■

Association iC60L-MA + Vigi iC60

iC60	Vigi iC60 25 A	Vigi iC60 40 A	Vigi iC60 63 A
1.6 A to 16 A	■	■	■
25 A	NO	■	■
40 A	NO	NO	■



Combining iC60 L-MA units with Vigi modules of higher rating.

PB104466-40

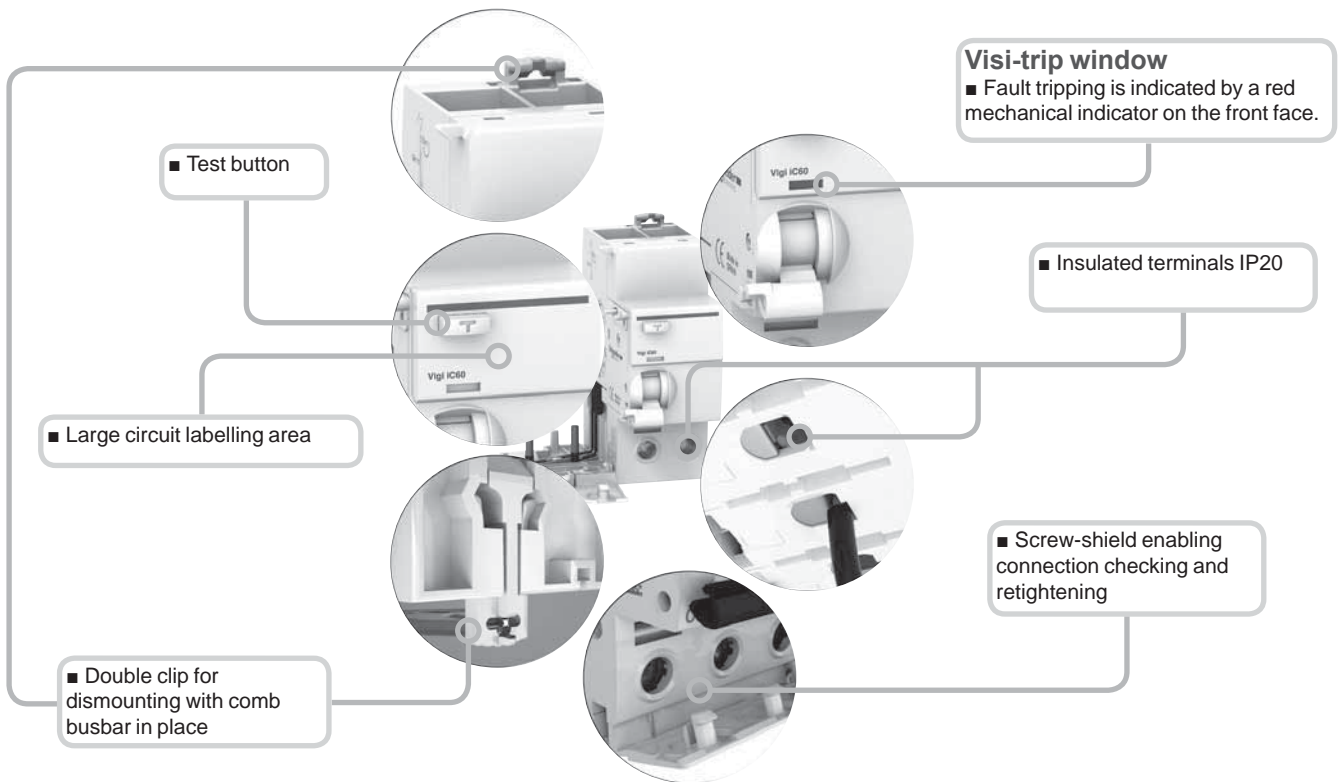

Asi type

The Asi type provides increased immunity from electrical interference and polluted or corrosive environments.

iID residual current circuit breakers (AC type)



IEC/EN 61008-1

PB104472-40



PB104473-40



- The iID residual current circuit breakers provide:
 - protection of persons against electric shock by direct contact (≤ 30 mA),
 - protection of persons against electric shock by indirect contact (≥ 100 mA),
 - protection of installations against the risk of fire (300 mA or 500 mA).

Catalogue numbers

iID residual current circuit breakers

Type	AC	Width in 9 mm module							
Product	iID								
2P	Sensitivity	10 mA	30 mA	100 mA	300 mA	500 mA	300 mA	500 mA	
	Rating	16 A	A9R10216	-	-	-	-	-	4
		25 A	A9R10225	A9R71225	-	A9R74225	A9R16225	-	
		40 A	-	A9R71240	A9R12240	A9R74240	A9R16240	-	
		63 A	-	A9R71263	A9R12263	A9R74263	A9R16263	A9R15263	-
		80 A	-	A9R11280	A9R12280	A9R14280	-	A9R15280	-
		100 A	-	A9R11291	A9R12291	A9R14291	-	A9R15291	-
	Rating	25 A	-	A9R71425	-	A9R74425	A9R16425	-	8
		40 A	-	A9R71440	A9R12440	A9R74440	A9R16440	A9R15440	A9R17440
		63 A	-	A9R71463	A9R12463	A9R74463	A9R16463	A9R15463	A9R17463
		80 A	-	A9R11480	A9R12480	A9R14480	A9R16480	A9R15480	A9R17480
		100 A	-	A9R11491	A9R12491	A9R14491	-	A9R15491	-
Voltage rating (Ue)	2P	230 - 240 V							
	4P	400 - 415 V							
Operating frequency		50/60 Hz							

iID residual current circuit breakers (A type)



IEC/EN 61008-1

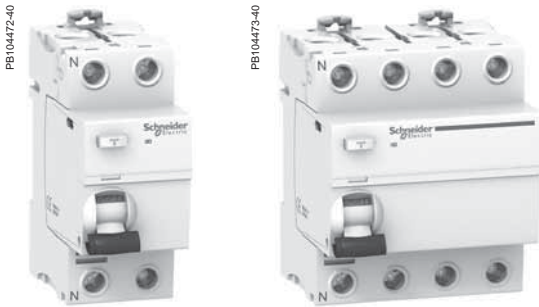

- The iID residual current circuit breakers provide:
 - protection of persons against electric shock by direct contact (≤ 30 mA),
 - protection of persons against electric shock by indirect contact (≥ 100 mA),
 - protection of installations against the risk of fire (300 mA or 500 mA).

Catalogue numbers

iID residual current circuit breakers									
Type	A iID							Width in 9 mm module	
Product	Sensitivity	10 mA	30 mA	100 mA	300 mA	500 mA	300 mA		
DB122476 	Rating 16 A 25 A 40 A 63 A 100 A	A9R20216	-	-	-	-	-	4	
		A9R20225	A9R51225	-	A9R54225	-	-		
		-	A9R51240	-	A9R54240	-	A9R25240		
		-	A9R51263	-	A9R54263	-	A9R25263		
		-	A9R21291	-	A9R24291	-	A9R25291		
DB122477 	Rating 25 A 40 A 63 A 80 A 100 A	-	A9R51425	-	A9R54425	-	-	8	
		-	A9R51440	A9R22440	A9R54440	A9R26440	A9R25440		
		-	A9R51463	A9R22463	A9R54463	A9R26463	A9R25463		
		-	A9R21480	-	A9R24480	-	A9R25480		
		-	A9R21491	-	A9R24491	A9R26491	A9R25491		
Voltage rating (Ue)	2P	230 - 240 V							
	4P	400 - 415 V							
Operating frequency	50/60 Hz								

iID residual current circuit breakers (Asi type)



IEC/EN 61008-1

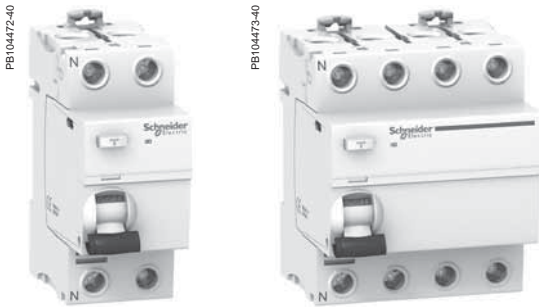

- The iID residual current circuit breakers provide:
 - protection of persons against electric shock by direct contact (≤ 30 mA),
 - protection of persons against electric shock by indirect contact (≥ 300 mA),
 - protection of installations against the risk of fire (300 mA or 500 mA).

The Asi type provides increased immunity from electrical interference and polluted or corrosive environments.

Catalogue numbers

iID residual current circuit breakers							
Type	Asi						Width in 9 mm module
Product	iID						
	Sensitivity	10 mA	30 mA	300 mA	300 mA	500 mA	
2P 	Rating	16 A	-	-	-	-	4
		25 A	A9R30225	A9R91225	-	-	
		40 A	-	A9R91240	-	A9R35240	
		63 A	-	A9R91263	-	A9R35263	
		100 A	-	-	-	A9R35291	
4P 	Rating	25 A	-	A9R91425	-	-	8
		40 A	-	A9R91440	-	A9R35440	
		63 A	-	A9R91463	A9R34463	A9R35463	
		80 A	-	A9R31480	-	A9R35480	
		100 A	-	A9R31491	A9R34491	A9R35491	
Voltage rating (Ue)	2P	230 - 240 V					
	4P	400 - 415 V					
Operating frequency	50/60 Hz						

iID residual current circuit breakers (AC, A, Asi types)

Connection

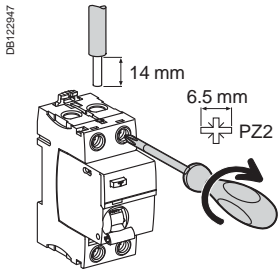

Type	Tightening torque	Without accessory		With accessories*			
		Copper cables		50 mm ² Al terminal	Screw-on connection for ring terminal	Multi-cables terminal	
		Rigid	Flexible or ferrule			Rigid cables	Flexible cables
iID	3.5 N.m	1 to 35 mm ²	1 to 25 mm ²	50 mm ²	Ø 5 mm	3 x 16 mm ²	3 x 10 mm ²

* See module CA907000

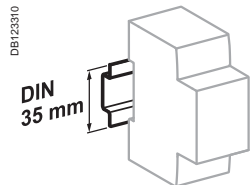

Clip on DIN rail 35 mm.

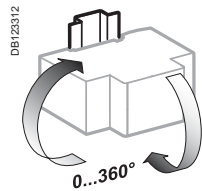

Indifferent position of installation.

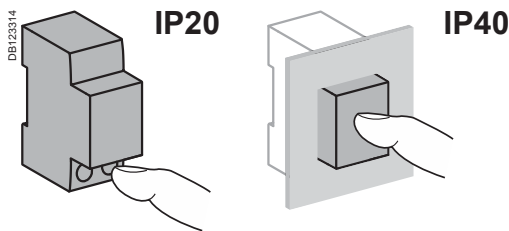

Technical data

Main characteristics

According to IEC 60947

Insulation voltage (U _i)	500 V
Pollution degree	3
Rated impulse withstand voltage (U _{imp})	6 kV

According to IEC/EN 61008-1

Making and breaking capacity (I _m /I _{Δm})	1500 A	
Surge current withstand (8/20 μs) without tripping	AC and A types (no selective \square)	250 kA
	AC, A types (selective \square)	3 kA
	Asi type	3 kA
Conditional rated short circuit current (I _{nc} /I _{Δc})	With iC60N/H/L	Equal to breaking capacity of iC60
	With fuse	10,000 A

Additional characteristics

Degree of protection	Device only	IP20	
	Device in modular enclosure	IP40 Insulation classe II	
Endurance (O-C)	Electrical (AC1)	16 to 63 A	15,000 cycles
		80 to 100 A	10,000 cycles
	Mechanical		20,000 cycles
Operating temperature	AC type		-5°C to +60°C
	A and Asi types		-25°C to +60°C
Storage temperature			-40°C to +85°C

iID residual current circuit breakers (AC, A, Asi types) (cont.)

Weight (g)

Residual current circuit breakers	
Type	iID
2P	210
4P	370

Dimensions (mm)

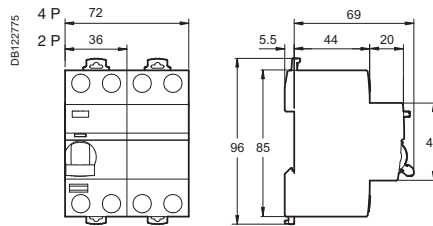

iID residual current circuit breakers (AC, A, Asi types) (cont.)

PE104548-40

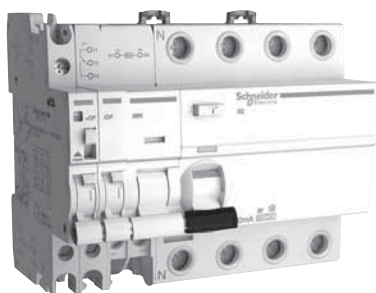

PE104472-40

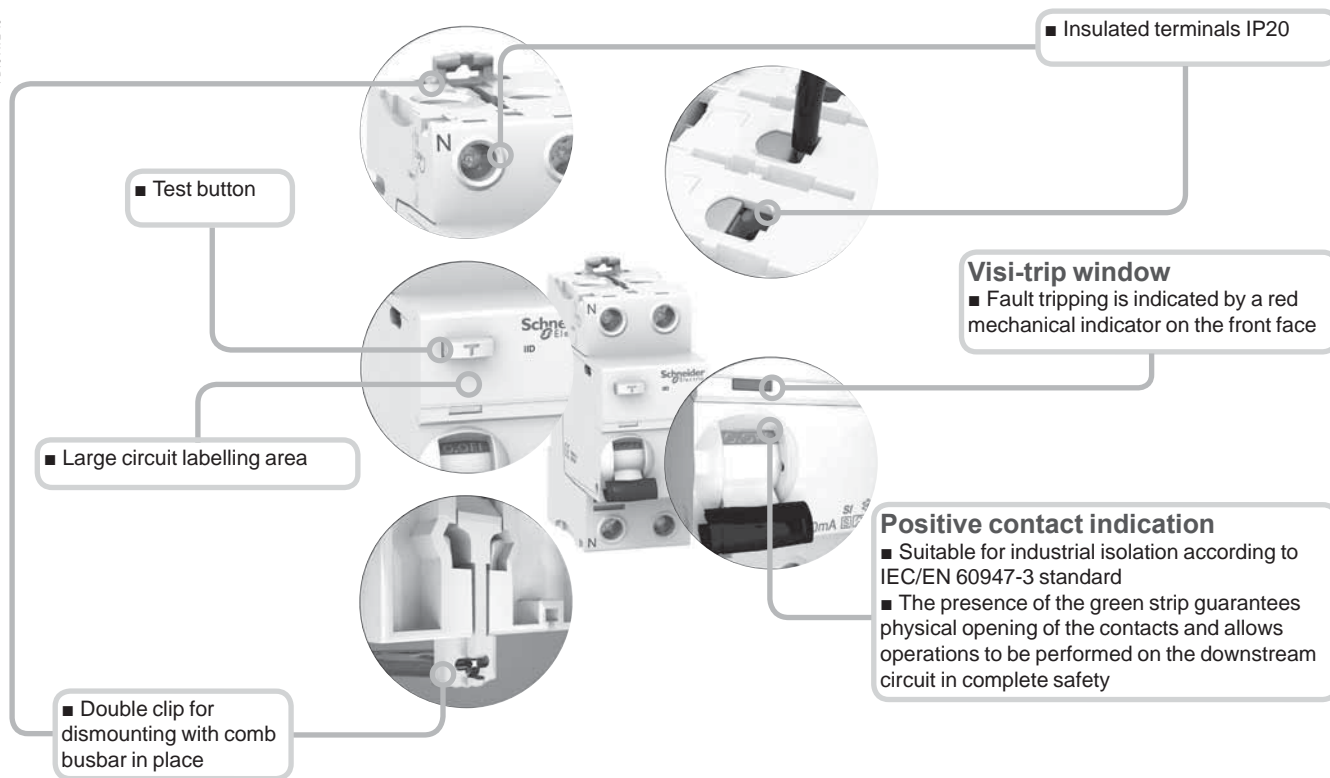

Asi type

The Asi type provides increased immunity from electrical interference and polluted or corrosive environments.

ARA automatic reclosers

For iC60 circuit breakers and iLD residual current circuit breakers

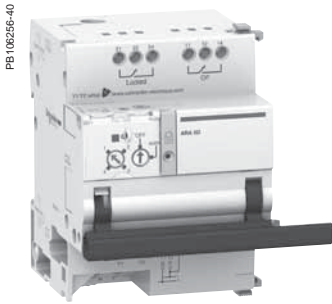

The ARA reclosing auxiliary can:

- Perform automatic reclosing of the associated protection device, after tripping.
- Increase the availability of installations without supervision, isolated, hard of access and demanding very great availability (mobile telephony systems, motorways, pumping stations, airports, railways, meteorological stations, service stations, automatic teller machines, public lighting, tunnels, etc.), by restoring them to operation without intervention by personnel in the event of a transient fault (atmospheric disturbances, industrial overvoltages, etc.).
- The operator can choose predefined reclosing program which allows the safety and availability of facilities to be reconciled taking into account the facility's environment.
- The circuit is placed in safety configuration by the padlocking device.

Catalogue numbers

ARA iC60				
For circuit breaker				Width in 9 mm modules
1P, 1P+N, 2P	Number of programs	Voltage		
	4	230 V AC, 50 Hz	A9C70132	7
3P, 4P				
	4	230 V AC, 50 Hz	A9C70134	7
ARA iLD				
For residual current circuit breaker				Width in 9 mm modules
2P	Number of programs	Voltage		
	1	230 V AC, 50 Hz	A9C70342	7
	4	230 V AC, 50 Hz	A9C70332	
4P				
	4	230 V AC, 50 Hz	A9C70334	7

Diagram

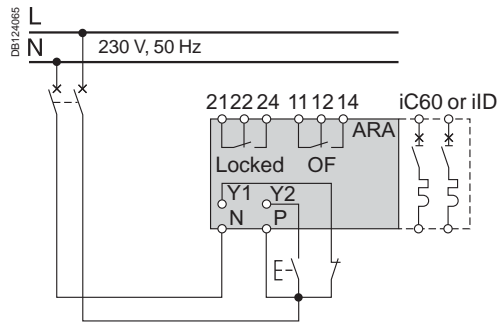

Legend		
Type		Application
1	2	Choice of program
4	3	
Y1		
Y2		Remote control of final reclosing
N		230 V power supply
P		
Locked		Automatic recloser inhibition indication contact
OF		Indicates the state of the circuit breaker or residual current circuit breaker (opened or closed)
Indicator lamp	Flashing green	Normal operation
	Flashing red	Reclosing cycle in progress
	Fixed red	Automatic recloser inhibited

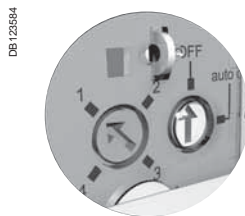
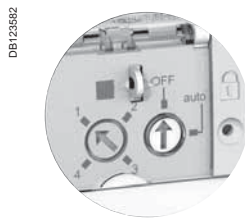

ARA automatic reclosers (cont.)

For iC60 circuit breakers and iID residual current circuit breakers

Operating principle

The ARA automatic recloser makes a number of attempts at reclosing depending on the program chosen by the user.

The program includes the following settings:

- A time delay before reclosing (TA).
- A reinitialization time delay (TB).
- A maximum number of reclosing attempts.

If, following these attempts, the fault is still present, the device places itself in waiting for manual reclosing, or final remote reclosing (Y2).

DB124062

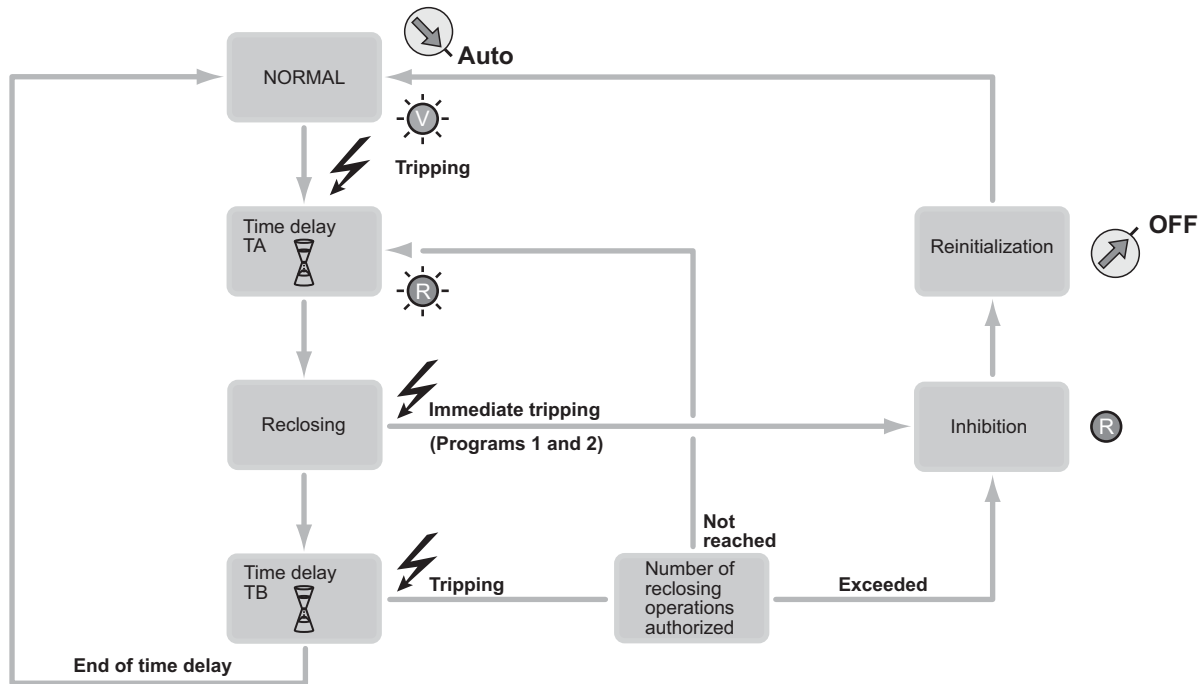

	iC60 1P, 1P+N, 2P: A9C70132 3P, 4P: A9C70134	iID 2P: A9C70342 2P: A9C70332 4P: A9C70334	Number of reclosing attempts	Delay before reclosing TA	Check time		Final reclosing Y2
					TB		
DB124061 1 2 4 3	■	-	1	60 s	6 min.		Once after inhibition
DB124062 1 2 4 3	■	-	3	60 s 3 min. 3 min.	2 min. 6 min. 6 min.		
DB124063 1 2 4 3	■	-	5	60 s 3 min. 3 min. 3 min.	2 min. 6 min. 6 min. 6 min.		
DB124064 1 2 4 3	■	-	5	60 s 3 min. 4 min. 5 min. 6 min.	2 min. 6 min. 8 min. 10 min. 12 min.		
DB124063 1 2 4 3	-	-	5	60 s 4 min. 10 min. 1 h 6 h	2 min. 3 min. 6 min. 10 min. 10 min.		Once per cycle
DB124064 1 2 4 3	-	-	15	20 s 40 s 3 min. 3 min. ...	30 min. 30 min. ...		
Only 1 program available	-	■	-	-	-	-	

ARA automatic reclosers (cont.)

For iC60 circuit breakers
and iID residual current circuit breakers

PE106950-78

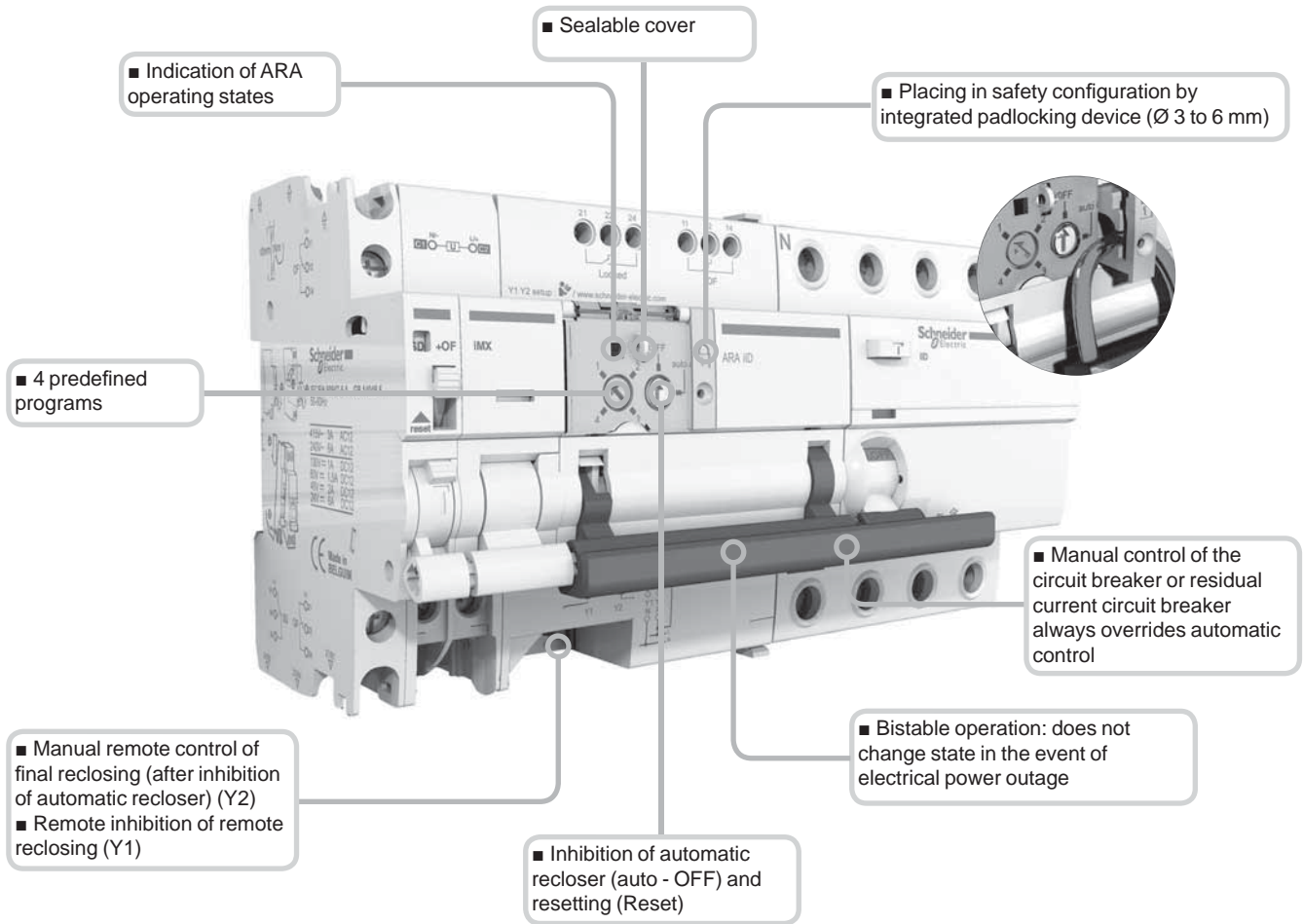

Indication auxiliaries	Tripping auxiliaries	ARA remote control	iC60 or iID device	Vigi iC60 add-on RCD
No	1 (iSD or iOF or iOF/SD+OF)	1 (iMX or iMN) max.		
1 iOF	1 (iSD or iOF or iOF/SD+OF)	No	<p>ARA</p>	<p>Vigi iC60</p>
			<p>iID</p>	-

ARA automatic reclosers (cont.)

For iC60 circuit breakers
and iID residual current circuit breakers

Connection

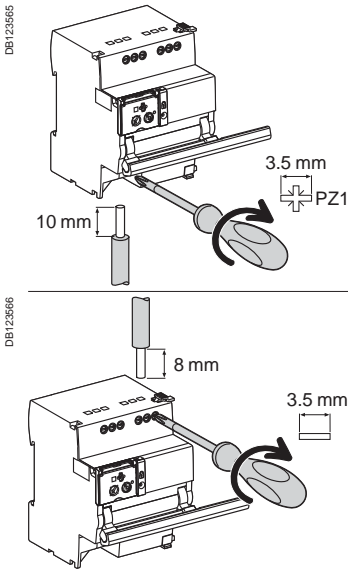

Terminal	Tightening torque	Without accessories		
		Copper cables Rigid	Flexible	Flexible with ferrule
Power supply (N/P) Inputs (Y1/Y2)	1 N.m	0.5 to 10 mm ² 2 x 0.5 to 2 x 2.5 mm ²	0.5 to 6 mm ² 2 x 0.5 to 2 x 2.5 mm ²	0.5 to 4 mm ² 2 x 0.5 to 2 x 2.5 mm ²
Outputs (OF/Locked)	0.7 N.m	0.5 to 2.5 mm ² 2 x 0.5 to 2 x 1.5 mm ²	0.5 to 2.5 mm ² 2 x 0.5 to 2 x 1.5 mm ²	0.5 to 1.5 mm ² 2 x 0.5 to 2 x 1.5 mm ²

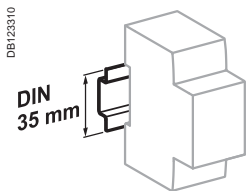

Clip on DIN rail 35 mm.

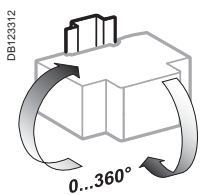

Indifferent position of installation.

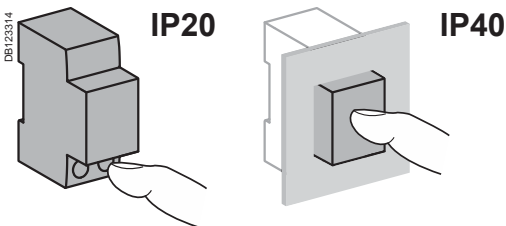

Technical data

Control circuit		
Supply voltage (Ue) (N/P)	230 V AC, 50 Hz	
Control voltage (Uc)	Type 1 inputs (Y1/Y2)	230 V AC (as per IEC 61131-2)
Min. duration of control order (Y2)	≥ 200 ms	
Response time (Y2)	< 500ms	
Consumption	≤ 1 W	
Thermal self-protection with automatic Reset against overheating of the control circuit due to an abnormal number of operations		
Endurance (O-C) (ARA combined with a circuit breaker)		
Electrical	5000 cycles	
Indication / Remote control		
Potential-free changeover contact output (OF/Locked)	Min.	24 V AC/DC, 10 mA
	Max.	230 V AC, 1 A
Input (Y1/Y2)	230 V AC	5 mA
Additional characteristics		
Degree of protection (IEC 60529)	Device only	IP20
	Device in a modular enclosure	IP40 Insulation class II
Insulation voltage (Ui)	400 V	
Degree of pollution (IEC 60947)	3	
Rated impulse withstand voltage (Uimp)	6 kV	
Operating temperature	-25°C to +60°C	
Storage temperature	-40°C to +70°C	
Tropicalization	Treatment 2 (relative humidity of 93 % at +40°C)	

ARA automatic reclosers (cont.)

For iC60 circuit breakers
and iLD residual current circuit breakers

Weight (g)

Automatic reclosers	
Type	ARA
For 1P, 1P+N, 2P circuit breakers or iLD 2P residual current circuit breaker	440
For 3P, 4P circuit breakers or iLD 4P residual current circuit breaker	470

Dimensions (mm)

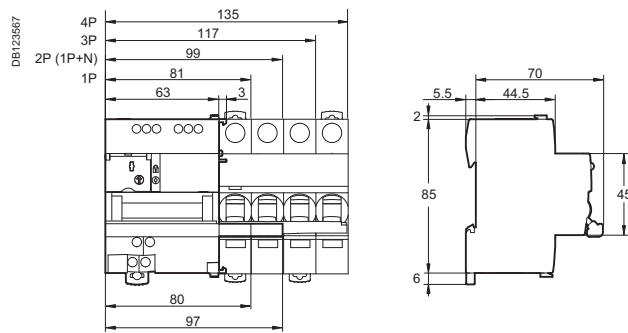



IEC/EN 61009



iDPNa Vigi



iDPN H Vigi

- The iDPN Vigi residual current device provide complete protection for final circuits (against overcurrents and insulation faults):
 - protection for users against electric shocks by direct contacts (y 30 mA),
 - protection for users against electric shocks by indirect contacts (300 mA),
 - protection of the installations against fire risks (300 mA).

- The *SI* range has been designed to maintain a network with optimum safety and continuity of service in installations disturbed by:
 - extreme atmospheric conditions,
 - harmonic generating loads,
 - transient operating currents.

iDPN N Vigi 6000

Type		AC		A			SI			Width in 9 mm modules		
1P+N Curve B	Sensitivity	30 mA	300 mA	10 mA	30 mA	100 mA	300 mA	30 mA	100 mA		300 mA	
 DB123871	Rating (In)	4 A	A9D55604	A9D68604	-	A9D556604	A9D60604	A9D69604	-	-	-	4
		6 A	A9D55606	A9D68606	-	A9D556606	A9D60606	A9D69606	-	-	-	
		10 A	A9D55610	A9D68610	A9D08610	A9D556610	A9D60610	A9D69610	-	-	-	
		13 A	-	-	-	A9D556613	A9D60613	A9D69613	-	-	-	
		16 A	A9D55616	A9D68616	A9D08616	A9D556616	A9D60616	A9D69616	-	-	-	
		20 A	A9D55620	A9D68620	-	A9D556620	A9D60620	A9D69620	-	-	-	
		25 A	A9D55625	A9D68625	-	A9D556625	A9D60625	A9D69625	-	-	-	
		32 A	A9D55632	A9D68632	-	A9D556632	A9D60632	A9D69632	-	-	-	
		40 A	A9D55640	A9D68640	-	A9D556640	A9D60640	A9D69640	-	-	-	
Voltage rating (Ue)		230 V AC										
Operating frequency		50 Hz										

iDPN H Vigi 10000

Type		A		SI		Width in 9 mm modules	
1P+N Curve B	Sensitivity	30 mA	300 mA	30 mA	300 mA		
 DB123871	Rating (In)	6 A	A9D07606	-	-	4	
		10 A	A9D07610	-	-		
		16 A	A9D07616	-	-		
		20 A	A9D07620	-	-		
		25 A	A9D07625	-	-		
		32 A	A9D07632	-	-		
 DB123871	Rating (In)	6 A	A9D37606	A9D47606	A9D38606	A9D48606	4
		10 A	A9D37610	A9D47610	A9D38610	A9D48610	
		16 A	A9D37616	A9D47616	A9D38616	A9D48616	
		20 A	A9D37620	A9D47620	A9D38620	A9D48620	
		25 A	A9D37625	A9D47625	A9D38625	A9D48625	
		32 A	A9D37632	A9D47632	A9D38632	A9D48632	
Voltage rating (Ue)		230 V AC					
Operating frequency		50 Hz					

Residual current devices iDPN Vigi (cont.)

■ Fast contact closure

■ Insulated terminals IP20

Visi-trip double window

- Fault tripping circuit breaker is indicated by a red mechanical indicator on the front face.
- Earth fault is indicated by a red mechanical indicator on the front face

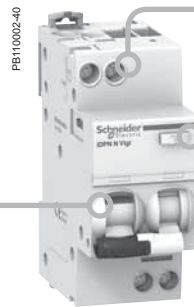

■ Test button

Positive contact indication

- A green strip on the toggle guarantees opening of all the poles in safety conditions (padlocking possible) for work to be carried out on live parts

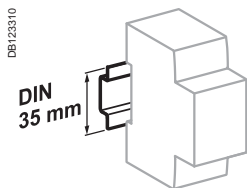

Clip on DIN rail 35 mm.

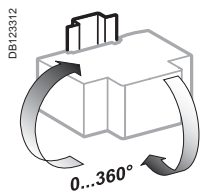

Indifferent position of installation.

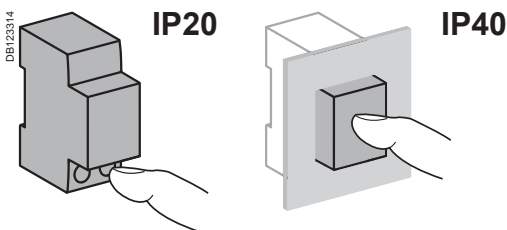

Connection

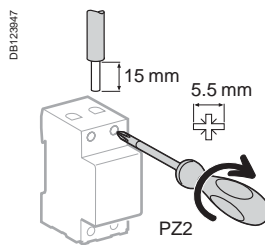

Rating	Tightening torque	Copper cables	
		Rigid	Flexible or ferrule
4 to 40 A	3.5 N.m	1 to 16 mm ²	1 to 10 mm ²

Technical data

Main characteristics			
	iDPN a Vigi	iDPN N Vigi	iDPN H Vigi
Insulation voltage (U _i)	400 V AC		
Pollution degree	3		
Rated impulse withstand voltage (U _{imp})	4 kV		
Setting temperature for ratings	30°C		
Magnetic tripping	Curve B	Between 3 and 5 I _n	
	Curve C	Between 5 and 10 I _n	
According to EN 61009			
Limitation class	3		
Rated breaking capacity (I _{cn})	4500 A	6000 A	10,000 A
Rated residual breaking and making capacity (I _{Δm})	4500 A	6000 A	10,000 A
8/20 μs impulse withstand	Type AC	250 Å	250 Å
	Type A	250 Å	250 Å
	Type SI	-	3 kÅ
Additional characteristics			
Earth leakage protection with instantaneous tripping	10, 30, 300 mA	10, 30, 100, 300 mA	30, 300 mA
Degree of protection (IEC 60529)	Device only	IP20	
	Device in modular enclosure	IP40 Insulation classe II	
Endurance (O-C)	Electrical	≤ 20 A	20,000 cycles
		≥ 25 A	10,000 cycles
	Mechanical	20,000 cycles	
Overvoltage category (IEC 60364)	III		
Operating temperature	Type AC	-5°C to +60°C	
	Type A, SI	-25°C to +60°C	
Storage temperature	-40°C to +85°C		
Topicalization (IEC 60068-1)	Treatment 2 (relative humidity 95 % to 55°C)		

Weight (g)

Residual current device	
Type	iDPN Vigi
1P+N	125

Dimensions (mm)

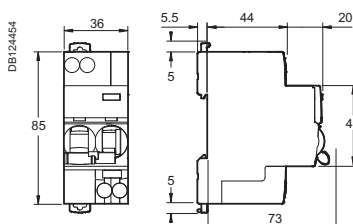

Electrical auxiliaries for iC60, iID, iSW-NA, RCA and ARA

■ The electrical auxiliaries are combined with iC60 circuit breakers, iID residual current circuit breakers, remote tripping switch disconnectors iSW-NA, RCA remote controls and ARA automatic reclosers; they enable tripping or remote indication of their position (open/closed/tripped) upon a fault.

■ They are fastened by clips (without tools) to the left side of the breaker.

■ The iOF/SD+OF auxiliary is a 2-in-1 product: via a mechanical selector switch, it provides two contacts, OF+SD or OF+OF.

IEC/EN 60947-1

■ Tripping auxiliaries:

- iMN: undervoltage release
- iMNs: delayed undervoltage release
- iMNx: undervoltage release, independant from supply voltage
- iMSU: overvoltage release
- iMX: shunt release
- iMX+OF: shunt release with open/close contact.

IEC/EN 60947-5-1

■ Indication auxiliaries:

- iOF: open/close contact
- iSD: fault indicating contact
- iOF/SD+OF: open/close contact and switchable OF or SD contact.



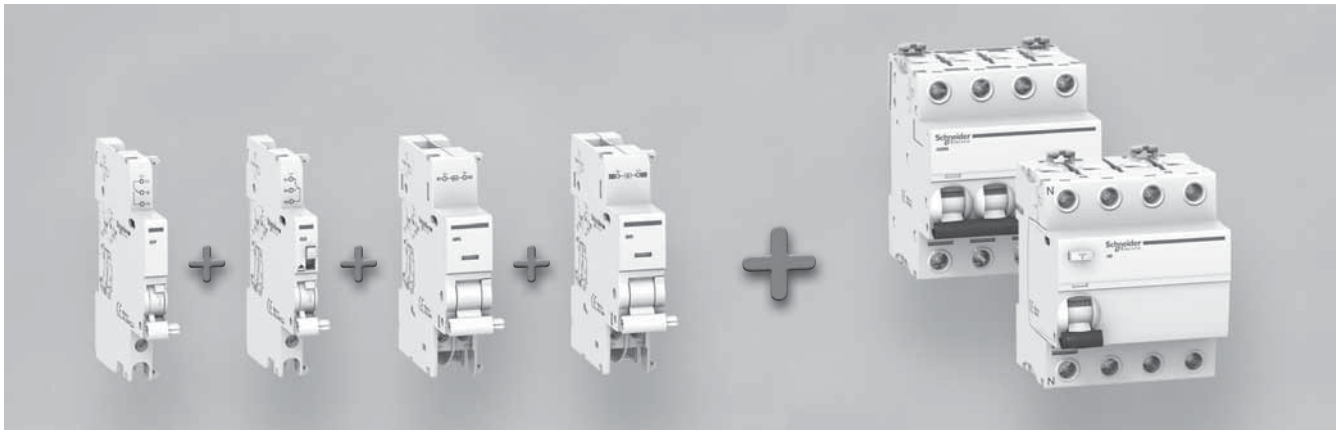







DB123545



Protection
Circuit protection
Earth leakage protection

Electrical auxiliaries for iC60, iID, iSW-NA, RCA and ARA (cont.)

Combination table

Electrical auxiliaries			Remote control	Devices	
Indication auxiliaries		Tripping auxiliaries	ARA automatic recloser or RCA remote control	iC60/iID/ iSW-NA*	Vigi
Position		Max quantity			
Left	Right				
1 iOF/SD+OF	+ 1 iOF/SD+OF	+ 1 (iMN, iMNs, iMNx or iMX, iMX+OF or iMSU)	-	 PB104440-25	 PB104466-25
Or 1 iOF	+ 1 (iSD or iOF or iOF/SD+OF)	+ 2 (iMN, iMNs, iMNx or iMX, iMX+OF or iMSU)			
Or None	+ None	+ 3 x iMSU			
None	+ 1 (iSD or iOF or iOF/SD+OF)	+ 1 (iMN, iMNs, iMNx or iMX, iMX+OF or iMSU)		 PB104472-25	-
Or 1 iOF	+ 1 (iSD or iOF or iOF/SD+OF)	+ None	 PB106256-25	 PB104440-25	 PB104466-25
None	+ 1 (iSD or iOF or iOF/SD+OF)	+ 1 (iMN, iMNs, iMNx or iMX, iMX+OF or iMSU)	 PB106253-25	 PB104472-25	-
Or 1 iOF	+ 1 (iSD or iOF or iOF/SD+OF)	+ None		 PB104440-25	 PB104466-25

Other possible associations: see technical pages







Tripping devices must be mounted first.

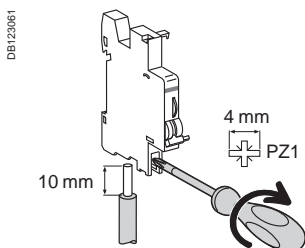



*iSW-NA : the iSD auxiliary contact must be associated with an auxiliary (iMN, iMX, iMX+OF); it indicates that the remote tripping switch disconnector has been tripped open.

Connection







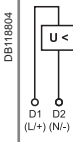
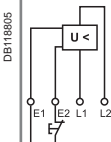
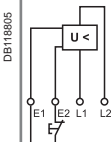
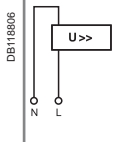

Type	Tightening torque	Copper cables		Multi-cables terminal	
		Rigid	Flexible	Rigid	With ferrule
Indication auxiliaries	1 N.m	 DB122345	 DB123007	 DB123011	 DB123008
Tripping auxiliaries	1 N.m	1 to 4 mm ²	0.5 to 2.5 mm ²	2 x 2.5 mm ²	2 x 1.5 mm ²
		1 to 6 mm ²	0.5 to 4 mm ²	2 x 2.5 mm ²	2 x 2.5 mm ²

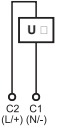
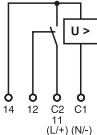

Electrical auxiliaries for iC60, iID, iSW-NA, RCA and ARA (cont.)

		Tripping							
Auxiliaries		iMN		iMNs		iMNx		iMSU	
Type		Undervoltage release						Overvoltage release	
		Instantaneous		Delayed		Independent of the supply voltage			
									
Function		<ul style="list-style-type: none"> Trips the device with which it is combined when its input voltage decreases (between 70 % and 35 % U_n). Prevents device closing again until its input voltage is restored 						<ul style="list-style-type: none"> Switches off the power supply by opening the breaker with which it is combined, in the event that the phase/neutral voltage is exceeded (loss of neutral). For a four-phase network, use three iMSU tripping auxiliaries 	
				<ul style="list-style-type: none"> Not tripping on transient voltage dip (up to 0.2 s) 		<ul style="list-style-type: none"> Separate input and power supply 		<ul style="list-style-type: none"> Tripping voltage: 275 V AC Tripping voltage: 255 V AC 	
Wiring diagrams									
Use		<ul style="list-style-type: none"> Emergency stoppage by normally closed push button Ensures the safety of power supply circuits for several machines by preventing "uncontrolled" restarting 				<ul style="list-style-type: none"> Emergency stoppage with fail-safe principle Insensitive to control circuit voltage variation to increase service continuity 		<ul style="list-style-type: none"> Protection of equipment against overvoltages on the electrical network (neutral conductor break) Voltage monitoring between phase and neutral conductors 	
Catalogue numbers		A9A26960	A9A26961	A9A26959	A9A26963	A9A26969	A9A26971	A9A26979	A9A26479
Technical specifications									
Rated voltage (U_e)	V AC	220...240	48	115	220...240	220...240	380...415	230	230
	V DC	–	48	–	–	–	–	–	–
Operating frequency	Hz	50/60	400	50/60	50/60	50/60	–	50/60	–
		–	–	–	–	–	–	–	–
Red mechanical indicator		On front face			On front face	On front face	–	On front face	–
Test function		–			–	–	–	–	–
Width in 9 mm modules		2			2	2	–	2	–
Operating current		–			–	–	–	–	–
Number of contacts		–			–	–	–	–	–
Operating temperature	°C	-35...+70			-35...+70	-35...+70	–	-35...+70	–
		–			–	–	–	–	–
Storage temperature	°C	-40...+85			-40...+85	-40...+85	–	-40...+85	–
		–			–	–	–	–	–

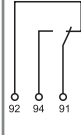
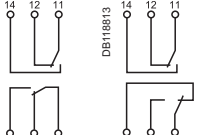



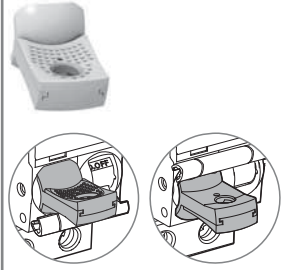
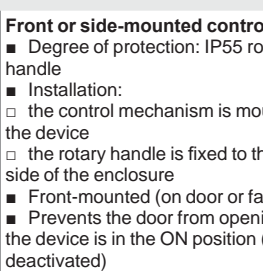
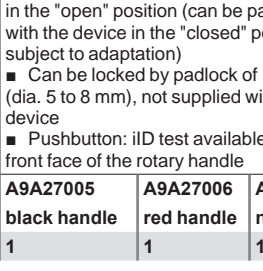

Electrical auxiliaries for iC60, iID, iSW-NA, RCA and ARA (cont.)

			Indication						
iMX			iMX+OF	iOF	iSD	iOF/SD+OF			
Shunt release				Open/close auxiliary contact	Fault indicating contact	Double open/close or fault indicating contact			
		With Open/Close auxiliary contact							
PB104496-35		PB104497-35		PB104474-35		PB104476-35		PB104475-35	
<ul style="list-style-type: none"> Trips the breaker when powered 			<ul style="list-style-type: none"> Changeover contact indicates "open" or "closed" position of the breaker 		<ul style="list-style-type: none"> Changeover contact indicates position of the breaker; upon: <ul style="list-style-type: none"> electrical fault action on tripping auxiliary Same indication as VISI-TRIP 		<ul style="list-style-type: none"> The iOF/SD+OF auxiliary is a 2-in-1 product: via a mechanical selector switch, it provides two contacts, OF+SD or OF+OF 		
			<ul style="list-style-type: none"> Includes an open/close contact (OF) to indicate the "open" or "closed" position of the breaker 						
DB123012		DB118808		DB118810		DB118811		DB118812	
							OF position		SD position
<ul style="list-style-type: none"> Emergency stoppage by normally open push button 			<ul style="list-style-type: none"> Emergency stoppage by normally open push button Remote indication of the position of the associated breaker 		<ul style="list-style-type: none"> Remote indication of the position of the associated breaker 		<ul style="list-style-type: none"> Remote indication of tripping upon a fault of the associated breaker 		<ul style="list-style-type: none"> Remote indication of position and/or tripping upon a fault of the associated breaker
A9A26476	A9A26477	A9A26478	A9A26946	A9A26947	A9A26948	A9A26924	A9A26927	A9A26929	
100...415	48	12...24	100...415	48	12...24	240...415	240...415	240...415	
110...130	48	12...24	110...130	48	12...24	24...130	24...130	24...130	
50/60			50/60		50/60		50/60		50/60
On front face			On front face		On front face		On front face		On front face
-			-		On toggle		On toggle		On toggle
2			2		1		1		1
-			y 24 V DC 6 A		24 V DC 6 A				
			48 V DC 2 A		48 V DC 2 A				
			y 130 V DC 1 A		60 V DC 1.5 A				
			y 240 V AC 6 A		130 V DC 1 A				
			415 V AC 3 A		240 V AC 6 A				
					415 V AC 3 A				
-			1 NO/NC		1 NO/NC		1 NO/NC		1 NO/NC + 1 NO/NC
-35...+70			-35...+70		-35...+70		-35...+70		-35...+70
-40...+85			-40...+85		-40...+85		-40...+85		-40...+85

Accessories for iC60, iID, iSW-NA, Reflex iC60, RCA and ARA

				Mounting		
Accessories	Rotary handle			Plug-in base	Padlocking device	
						
						
						
Function	<p>Front or side-mounted control</p> <ul style="list-style-type: none"> ■ Degree of protection: IP55 rotary handle ■ Installation: <ul style="list-style-type: none"> □ the control mechanism is mounted on the device □ the rotary handle is fixed to the front or side of the enclosure ■ Front-mounted (on door or faceplate) <ul style="list-style-type: none"> ■ Prevents the door from opening when the device is in the ON position (can be deactivated) ■ Can be padlocked when the device is in the "open" position (can be padlocked with the device in the "closed" position subject to adaptation) ■ Can be locked by padlock of (dia. 5 to 8 mm), not supplied with the device ■ Pushbutton: iID test available in the front face of the rotary handle 			<ul style="list-style-type: none"> ■ The Laser Square tool brings the accuracy to align the circuit breaker and the rotary handle 	<p>Allows a breaker to be removed or replaced quickly, without handling the connections</p> <ul style="list-style-type: none"> ■ Degree of protection: IP20 ■ Consists of: <ul style="list-style-type: none"> □ a base to be fastened on a rail (or panel) □ 2 "blades" to be fastened in the device's terminals ■ Connection: tunnel terminals for cable up to 35 mm² rigid, 25 mm² flexible, <ul style="list-style-type: none"> ■ Installation: <ul style="list-style-type: none"> □ in universal enclosure □ on horizontal rail ■ Height: 178 mm ■ Not compatible with Vigi iC60 and auxiliaries <ul style="list-style-type: none"> ■ Can be locked by padlock of (dia. 6 mm), not supplied with the device 	<p>Used to padlock breaker in open or closed position</p> <ul style="list-style-type: none"> ■ Padlock diameter: 3 to 6 mm ■ Sealable (max. diameter: 1.2 mm) ■ Locking in ON position does not prevent tripping of the breaker in the event of faults ■ Suitable for IEC/EN 60947-2 compliant disconnection
Catalogue numbers	A9A27005 black handle	A9A27006 red handle	A9A27008 no handle	GVP01	A9A27003 (1 per pole)	A9A26970
Set of	1	1	1	1	1	10
Suitability						
iC60	■ 2P, 3P, 4P					■
iC60 + Vigi iC60	■ 2P, 3P, 4P					■
iID	■				■ ≤ 63 A	■
Reflex iC60 or RCA+iC60 or ARA+iC60	-					■
ARA+iID	-					■
iSW-NA	■					■

Accessories for iC60, iID, iSW-NA, Reflex iC60, RCA and ARA (cont.)

		Security					
Accessories		Screw shield		Terminal shield		Inter-pole barrier	Spacer
							
Function		Prevents any contact with the connecting screws <ul style="list-style-type: none"> Upgrades degree of protection to IP20D Sealable, max. diameter 1.2 mm 		Prevents any contact with the terminals <ul style="list-style-type: none"> Upgrades degree of protection to IP20D Sealable, max. diameter 1.2 mm Set of two, for upstream and downstream terminals For 3 poles: A9A26975 + A9A26976 For 4 poles: 2 X A9A26976 		Enhances insulation between connections: cables, terminals, lugs, etc <ul style="list-style-type: none"> Used to: <ul style="list-style-type: none"> complete rows separate devices. Width: 1 x 9 mm module Allows cable routing from one row to another, (above and below), up to 6 mm² 	
Catalogue numbers		A9A26982	A9A26981	A9A26975	A9A26976	A9A27001	A9A27062
Set of		12 x 1 pole	20 x 4 poles (splittable)	2 x 1 pole	2 x 2 poles	10	5
Suitability							
iC60		–	■	■	■	■	■
Vigi iC60		■	–	–	–	–	■
iID		–	■	–	■	■	■
Reflex iC60 or RCA+iC60 or ARA+iC60		–	■	■	■	■	■
ARA+iID		–	■	–	■	■	■
iSW-NA		–	■	–	■	■	■

Accessories for iC60, iLD, iSW-NA, Reflex iC60, RCA and ARA (cont.)

Dimensions (mm)

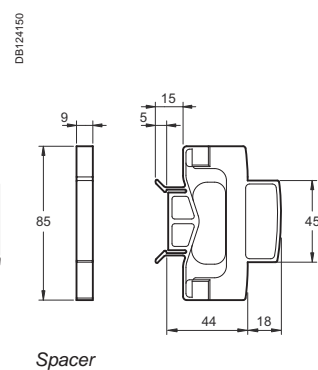
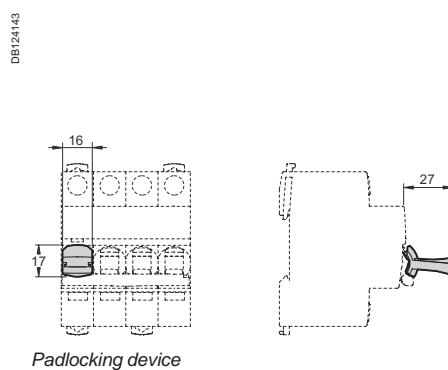
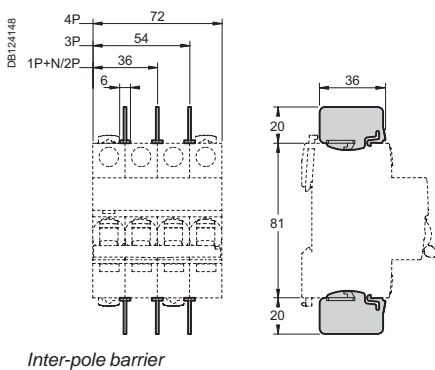
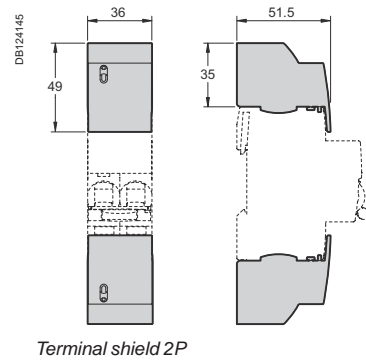
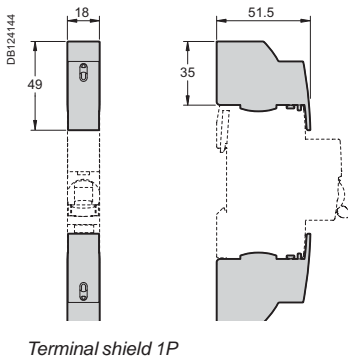
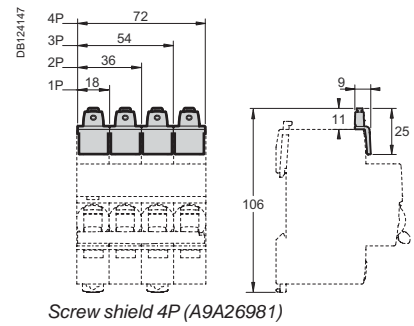
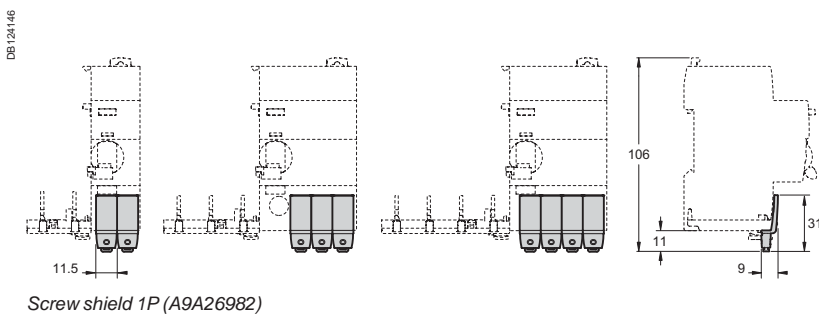
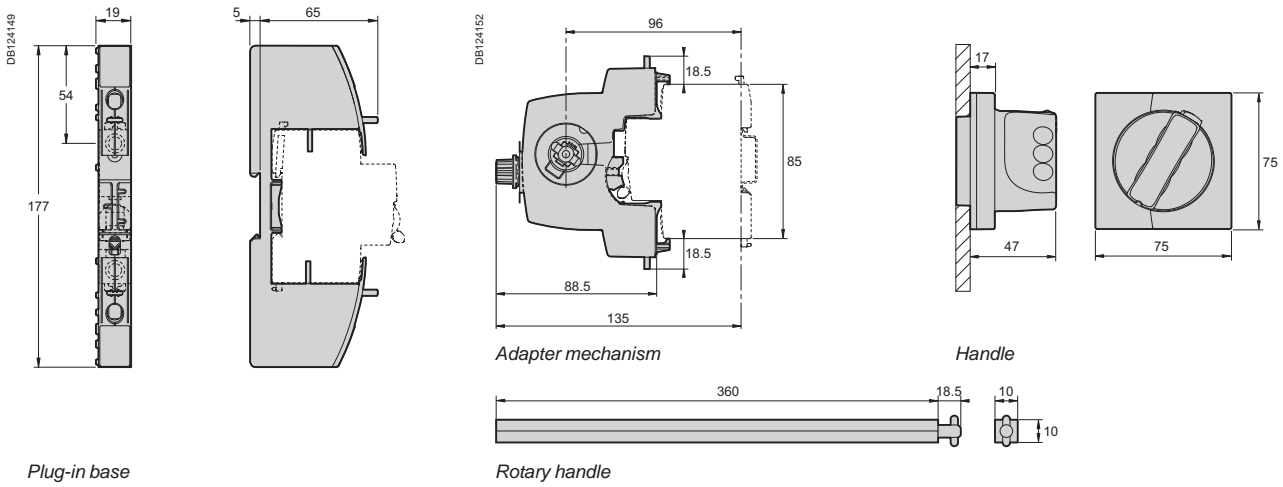

Rotary handle installation

Dimensions (mm)

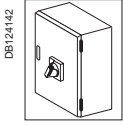

iC60	Z (mm)
2P	25.3
2P + Vigi	25.3
3P	25.3
3P + Vigi	43
4P	43
4P + Vigi	43

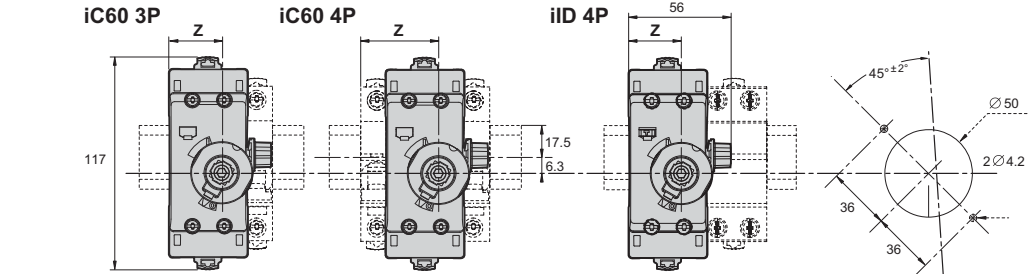

iID	Z (mm)
2P	25.3
4P	25.3

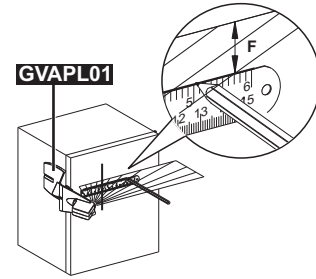
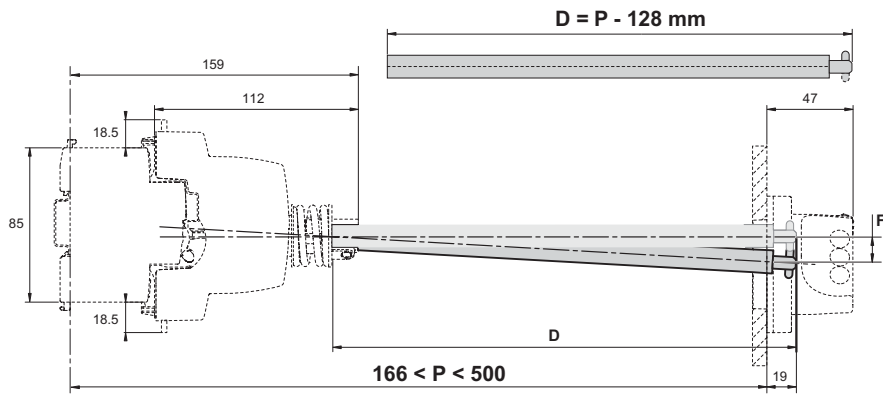

P (mm)	F (mm)
300	5
500	11

Rotary handle: front mounted control

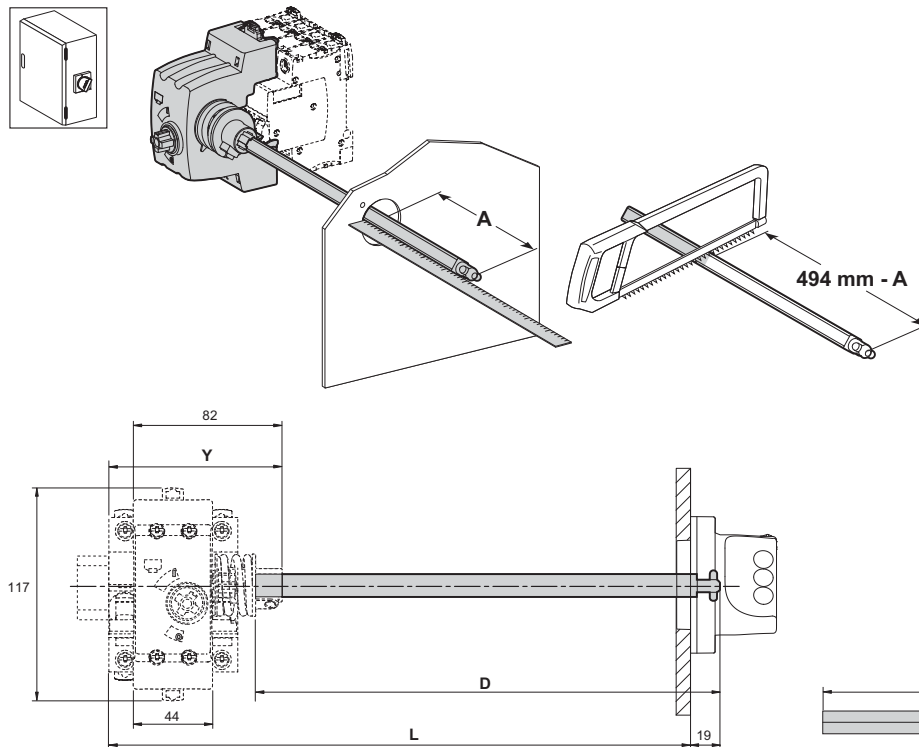
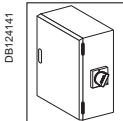

iC60	X (mm)	Y (mm)
2P	44.5	76.8
2P + Vigi	44.5	76.8
3P	44.5	76.8
3P + Vigi	62	94.5
4P	62	94.5
4P + Vigi	62	94.5

iID/iSW-NA	X (mm)	Y (mm)
2P	44.5	76.8
4P	44.5	76.8



Rotary handle: side mounted control

iK60N circuit breakers (curve C)

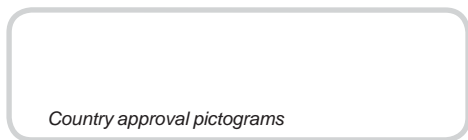

IEC/EN 60898-1

PB104463-40



PB104463-40



- iK60N circuit breakers are circuit breakers which combine the following functions:
 - circuit protection against short-circuit currents,
 - circuit protection against overload currents,
 - disconnection, opening and closing.

iK60N circuit breaker 50/60 Hz		Service breaking capacity (Ics) 100 % of Icn
Breaking capacity in short circuit (Icn) as per IEC/EN 60898-1		
Ph/Ph	400 V	
Ph/N	230 V	
Rating (In) 6 to 32 A	6000 A	

Catalogue numbers

iK60N circuit breakers				
Type	1P	2P	3P	4P
Rating (In)	Curve C	Curve C	Curve C	Curve C
6 A	A9K27106	A9K27206	A9K24306	A9K24406
10 A	A9K27110	A9K27210	A9K24310	A9K24410
16 A	A9K27116	A9K27216	A9K24316	A9K24416
20 A	A9K27120	A9K27220	A9K24320	A9K24420
25 A	A9K27125	A9K27225	A9K24325	A9K24425
32 A	A9K27132	A9K27232	A9K24332	A9K24432
Operating frequency	50/60 Hz	50/60 Hz	50/60 Hz	50/60 Hz
Width in 9-mm modules	2	4	6	8

iK60N circuit breakers (curve C) (cont.)

PB104934-40

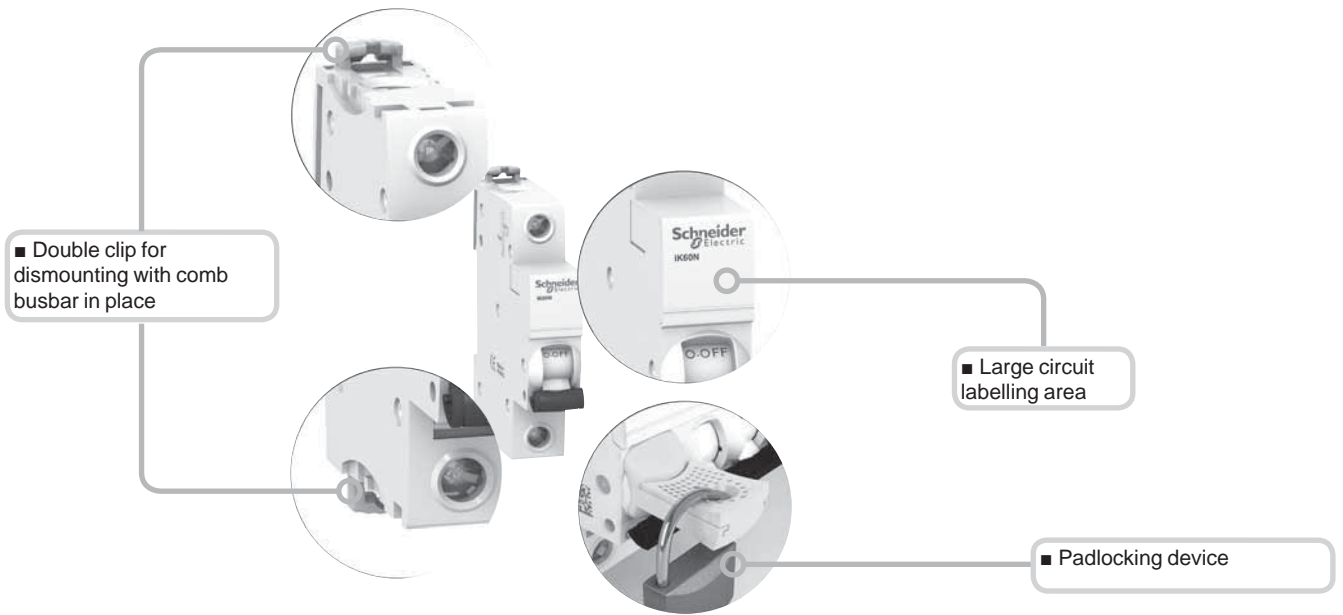

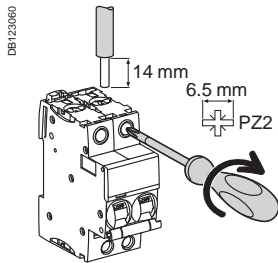

- Fast closing independent of the speed of actuation of the toggle.
- Top or bottom electrical feeding.

Connection



DB122940

Type	Rating	Tightening torque	Without accessory	
			Copper cables	
			Rigid	Flexible or ferrule
C curve	1 to 32 A	2 N.m		
	40 to 63 A	3.5 N.m		

DB122945

DB122946

iK60N circuit breakers (curve C) (cont.)

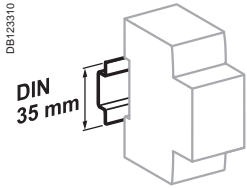

Encliquetage sur rail DIN de 35 mm.

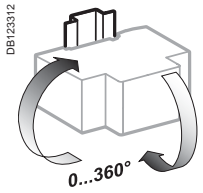

Position d'installation indifférente.

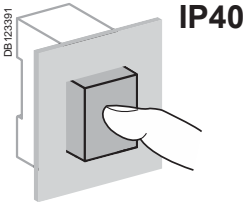

Technical data

Main characteristics		
According to IEC/EN 60898-1		
Insulation voltage (U _i)		440 V AC
Pollution degree		2
Rated impulse withstand voltage (U _{imp})		4 kV
Thermal tripping	Reference temperature	30°C
	Temperature derating	See module CA908007
Magnetic tripping	C curve	5 to 10 I _n
Limitation class		3
Rated making and breaking capacity of an individual pole (I _{cn1})		I _{cn1} = I _{cn}
Additional characteristics		
Degree of protection (IEC 60529)	Device in modular enclosure	IP40 Insulation class II
Endurance (O-C)	Electrical	10,000 cycles
	Mechanical	20,000 cycles
Overvoltage category (IEC 60364)		III
Operating temperature		-25°C to +60°C
Storage temperature		-40°C to +85°C

Weight (g)

Circuit-breaker	
Type	iK60N
1P	100
2P	200
3P	300
4P	400

Dimensions (mm)

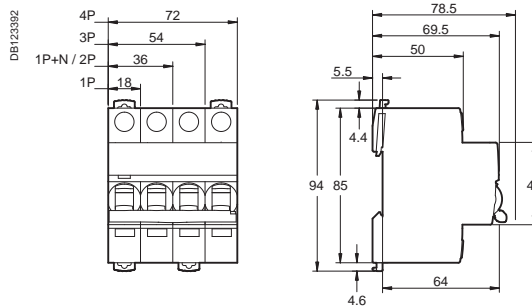

iID K residual current circuit breakers



IEC/EN 61008-1

- The iID K residual current circuit breakers provide:
 - protection of persons against electric shock by direct contact (30 mA),
 - protection of persons against electric shock by indirect contact (300 mA)
 - protection of installations against the risk of fire (300 mA).



Catalogue numbers

iID K residual current circuit breakers					
Type		AC		Width in 9-mm modules	
Product		iID K			
Auxiliaries		Without auxiliaries			
2P 	Sensitivity Rating	30 mA	300 mA	4	
		25 A	A9R50225		A9R75225
		40 A	A9R50240		A9R75240
4P 	Sensitivity Rating	30 mA	300 mA	8	
		25 A	A9R50425		A9R75425
		40 A	A9R50440		A9R75440
	63 A	A9R70463	A9R75463		
Voltage rating (Ue)	2P	230 - 240 V			
	4P	400 - 415 V			
Operating frequency		50/60 Hz			

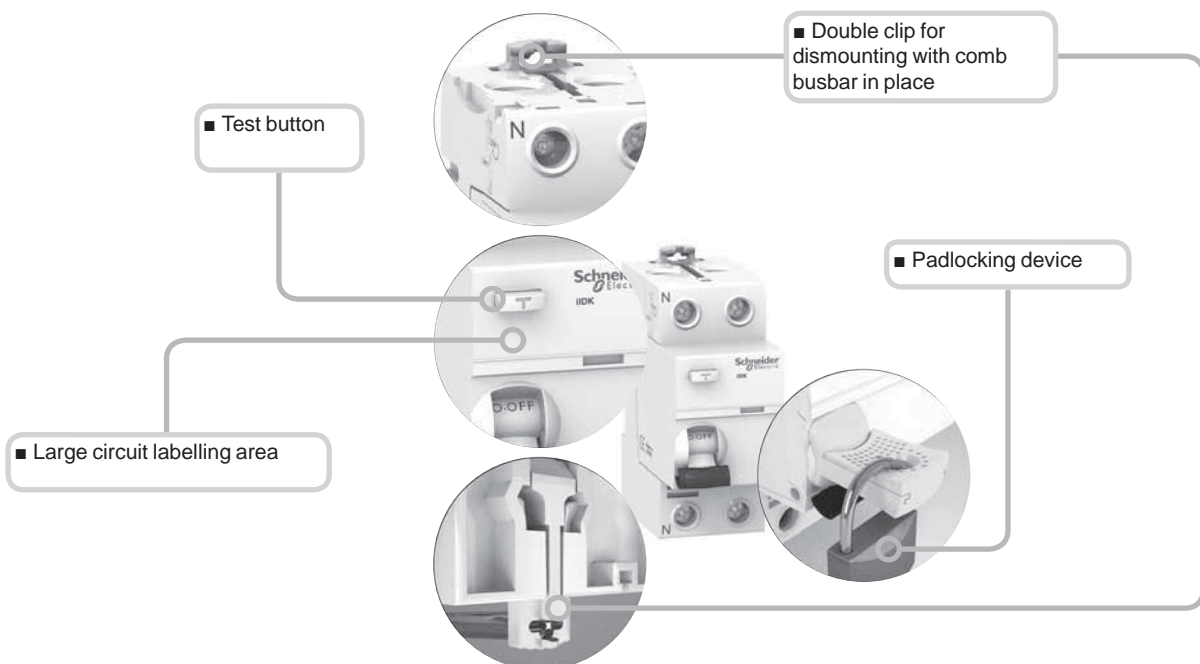

iID K residual current circuit breakers (cont.)

Connection

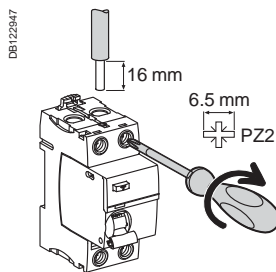

Type	Tightening torque	Without accessory	
		Copper cables Rigid	Flexible or ferrule
iID K	3.5 N.m	1 to 35 mm ²	1 to 25 mm ²

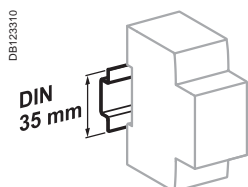

Clip on DIN rail 35 mm.

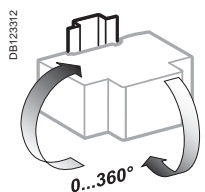

Indifferent position of installation.

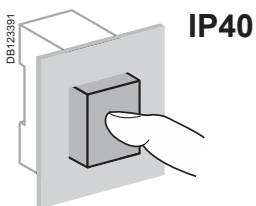

Technical data

Main characteristics

According to IEC/EN 61008-1

Insulation voltage (U _i)	440 V
Pollution degree	2
Rated impulse withstand voltage (U _{imp})	4 kV
Making and breaking capacity (I _m /I _{Δm})	25 to 40 A 500 A 63 A 630 A
Surge current withstand (8/20 μs) without tripping	Up to 200 Å
Conditional rated short circuit current (I _{nc} /I _{Δc})	With iC60N/H/L, iK60N 6000 A With fuse 4500 A

Additional characteristics

Degree of protection	Device in modular enclosure	IP40
Endurance (O-C)	Electrical	2000 cycles (AC1)
	Mechanical	5000 cycles
Operating temperature		-5°C to +60°C
Storage temperature		-40°C to +85°C

Weight (g)

Residual current circuit breakers

Type	iID K
2P	210
4P	370

Dimensions (mm)

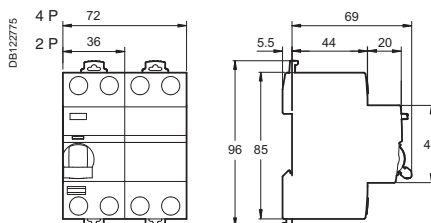

PE104507-35

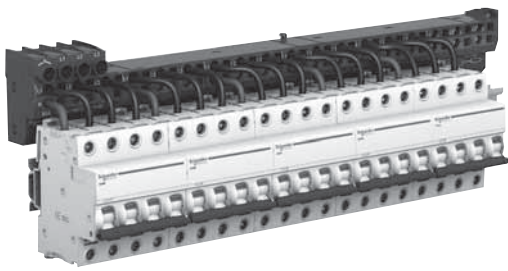

IEC/EN 60947-7-1.
IEC/EN 61439-2.

Description

- Multiclip 80 A is a four-pole splitter block 24 modules wide installable on a standard DIN rail.
- Outgoing feeders are connected at the front, without screws, in spring terminals.
- The spring contact pressure adapts automatically to the cross section of the conductor. It is independent of the operator.
- Supplied with 12 black and 12 blue pre-stripped 6 mm² cables.

DB122626

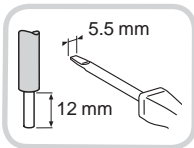
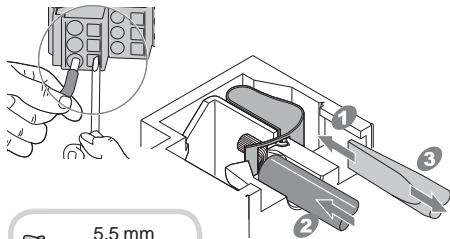

Advantages

- Very fast connection.
- Very simple phase rebalancing.
- In the event of an extension to or modification of the switchboard, connection is very easy.
- Compatible with inter-rows of 150 mm.

Technical data

Main characteristics	
Cat. no	04000
According to IEC/EN 60947-7-1	
Rated current at 40°C (I _n)	80 A
Maximum operated voltage (U _e)	440 V AC
Operating frequency	50/60 Hz
Rated insulation voltage (U _i)	500 V AC
Pollution degree	3
Rated impulse withstand voltage (U _{imp})	6 kV
Degree of protection	IP20
Short-circuit current withstand	Up to breaking capacity of Schneider Electric outgoing circuit breakers, even when reinforced by cascading implementation
Width in 9-mm modules	48

Power supply

- Four-pole tunnel terminals with screw clamping.
- The tunnel terminals are located to facilitate the insertion of cables and clamping by screws.
- One cable per connection point:
 - flexible from 6 to 25 mm²
 - rigid from 10 to 35 mm².

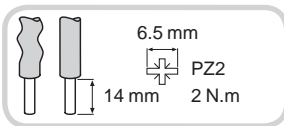

PE104501-45

Installation

- Clip-on mounted Pragma and Prisma DIN rails.
- Screwed on all other symmetric rail.



Distribution

- Connection to spring terminals through the front.
- 2 rows of terminals:
 - 18 connection points for phases (L1, L2, L3)
 - 18 connection points for neutral.
- A single cable per connection point: flexible (without ferrule) or rigid from 1 to 6 mm².
- Maintenance-free (tightness guaranteed over time). Insensitive to vibrations and thermal variations.

Multiclip 80 A splitter block (cont.)

PB 104905-50



Additional characteristics

According to IEC/EN 61439-2

Operating temperature	-25°C to +60°C
Storage temperature	-40°C to +85°C
Colour	RAL 7016

Installation

DB123198

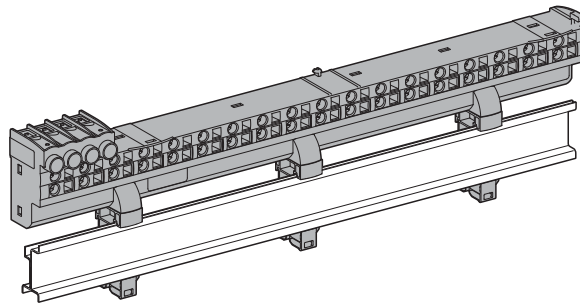

On Pragma and Prisma rails

DB123199

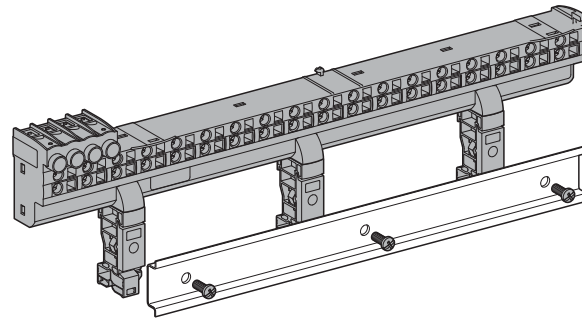

On other symmetric rails

Weight (g)

Splitter block

Type

Multiclip	640
-----------	-----

Dimensions (mm)

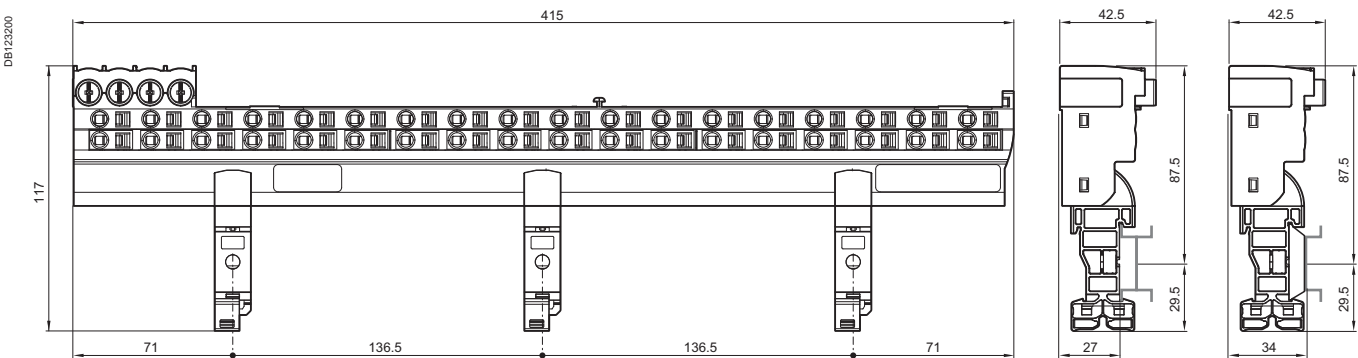

Earth leakage protection

Response time of medium-sensitivity residual current devices

Response time of iC60 Vigi and iID60 residual current devices

The medium-sensitivity residual current devices (100...1000 mA) in the Acti9 range conform to IEC/EN 61008 and 61009:

- their response time guarantees personal protection against indirect contacts and fire risks
- in the case of selective versions (S), a "non-tripping time" guarantees discrimination with the residual current devices installed downstream.

Instantaneous residual current devices

		Sensitivity (I Δ n)			
		100 mA	300 mA	500 mA	
Fault current (mA)	I Δ n/2	50	150	250	No tripping
		Max. response time			
	I Δ n	100	300	500	300 ms
	2 x I Δ n	200	600	1000	150 ms
	5 x I Δ n	500	1500	2500	40 ms
	500 A				40 ms

Selective (S) and time-delayed (R) residual current devices

Residual current device		Sensitivity (I Δ n)				Type			
		100 mA	300 mA	500 mA	1000 mA	Selective (S)		Time-delayed (R)	
Fault current (mA)	I Δ n/2	50	150	250	500	No tripping		No tripping	
						Non-tripping time	Response time	Non-tripping time	Response time
	I Δ n	100	300	500	1000	130 ms	500 ms	300 ms	1000 ms
	2 x I Δ n	200	600	1000	2000	60 ms	200 ms	150 ms	500 ms
	5 x I Δ n	500	1500	2500	5000	50 ms	150 ms	150 ms	300 ms
	500 A					40 ms	150 ms	150 ms	300 ms

Definitions

Response time

Time between the appearance of a hazardous leakage current and circuit power down.

Non-tripping time

For selective and time-delayed devices, the non-tripping time is the time between the appearance of a hazardous leakage current and the device tripping.

If the leakage current disappears before this time, the device does not trip.

This fast disappearance of the leakage current can be due to:

- the transient nature of the fault (e.g. the current generated by a switching surge)
- the interruption of the fault current by another faster residual current device situated downstream.

Selective and time-delayed devices therefore afford the user:

- better immunity against nuisance tripping
- total discrimination between residual current devices.

Earth leakage protection

Response time of medium-sensitivity residual current devices

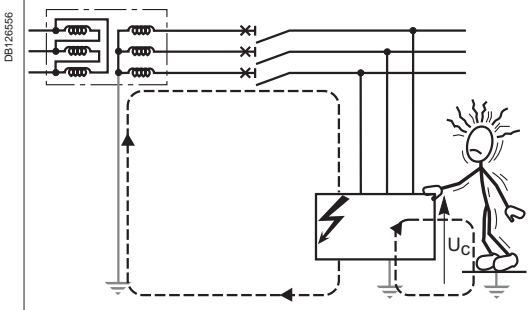

Protection against indirect contacts

The response times of residual current devices guarantee personal protection against indirect contacts, in conformance with the requirements of the installation standards (IEC 60364 or equivalent).

Indirect contacts

A person who comes into contact with an accidentally live frame caused by an insulation fault experiences an indirect contact: the contact voltage U_c creates a current that passes through the human body.

Maximum breaking time

The maximum breaking time required by the installation standards, in the event of an insulation fault, depends on:

- the network voltage
- the earthing system.

Maximum breaking time for terminating circuits (ms)

Earthing system	Network phase/neutral voltage			
	50...120V	120...230V	230...400V	> 400 V
TN or IT	800	400	200	100
TT	300	200	70	40

Note: a breaking time of no more than 5 s is permitted for distribution circuits to ensure discrimination with the devices installed on the terminating circuits. This time should be reduced to the essential minimum.

These times are based on the maximum prospective values of the contact voltage U_c and on the contact times authorised by technical report IEC 60479.

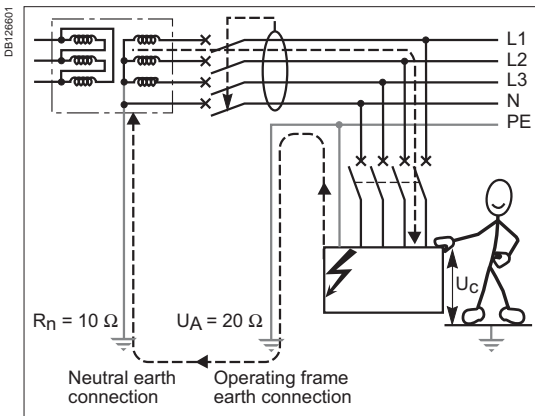

Example

On a three-phase phase/neutral voltage network $U_0 = 230$ V in a TT system:

- the resistance of the neutral earth connection R_n is 10Ω ,
- the resistance of the operating frame earth connection R_A is 100Ω .

In the event of an insulation fault, the leakage current I_d is equal to: $U_0 / (R_A + R_n)$ i.e. $230 \text{ V} / 110 \Omega = 2.1 \text{ A}$.

The contact voltage U_c is therefore $I_d \times R_A$ i.e. $2.1 \text{ A} \times 100 \Omega = 210 \text{ V}$.

■ Protection sensitivity

The residual current device must trip as soon as the leakage current corresponds to a hazardous situation, i.e. a contact voltage of 50 V (in a dry atmosphere). Hence, $I_{\Delta n} = 50 \text{ V} / R_A$, i.e. $50 \text{ V} / 100 \Omega = 500 \text{ mA}$.

■ Maximum breaking time

For a 230 V phase/neutral voltage network in a TT system, the IEC 60364 standard requires a maximum breaking time of 200 ms.

For the 2.1 A leakage current:

- an instantaneous residual current device with a sensitivity of 300 mA will power down the circuit in less than 40 ms,
- an instantaneous residual current device with a sensitivity of 500 mA will power down the circuit in less than 60 ms.

Note: For well-designed and regularly maintained electrical installations, the resistance of the operating frame earth connection can be less than 100Ω .

Use of the time-delayed residual current devices

In accordance with the breaking times required by the installation standards (above), the selective and time-delayed residual current devices can be used in the following cases:

Circuit	Network voltage (phase/neutral)	Residual current device		
		Instantaneous I	Selective S	Time-delayed R
Terminating circuit	$\leq 230 \text{ V}$	■	■	(1)
	$> 230 \text{ V}$	■		
Sub-distribution or general		■	■	■

(1) Only in a TN system for a phase/neutral voltage < 120 V.

Earth leakage protection

Response time of medium-sensitivity residual current devices

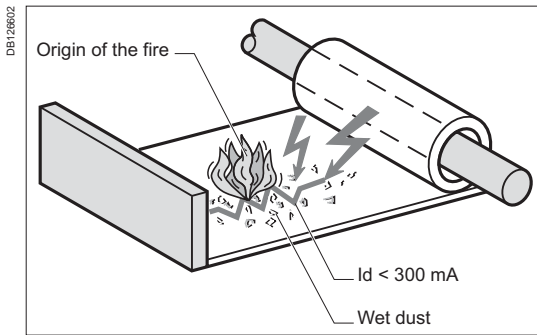

Protection against fire hazards

Most fires of electrical origin are caused by the creation and propagation of electric arcs in building materials, in the presence of moisture, dust, pollution, etc. These arcs appear and develop due to the wear and tear or ageing of the insulating materials. The fire risk occurs when the leakage currents reach a few hundred milliamps for a few seconds.

For fault currents of this magnitude, residual current devices with a sensitivity of 300 or 500 mA trip in less than a second, whether they be instantaneous, selective or time-delayed.

The response times of residual current devices with a sensitivity of 300 mA guarantee protection against fires generated by leakage currents

IEC 60364-4-42 (subclause 422.3.10) states that it is mandatory to install a residual current device with a sensitivity less than or equal to 500 mA:

- on premises with a risk of explosion (BE3)
- on premises with a risk of fire (BE2)
- in agricultural and horticultural buildings
- for circuits supplying fair, exhibition and entertainment equipment
- on temporary outdoor leisure facilities.

In certain countries, the installation rules and/or local safety regulations require a sensitivity of 300 mA.

Earth leakage protection

Response time of medium-sensitivity residual current devices

Discrimination of residual current devices

The non-tripping times of type (S) and (R) residual current devices ensure discrimination with the residual current devices located downstream.

Combination rules

To ensure discrimination between two cascading residual current devices, the following two conditions must be met simultaneously:

- the sensitivity of the upstream device must be at least 3 times the sensitivity of the downstream residual current device
- the upstream residual current device must be one of the following types:
 - Selective (S) if the downstream residual current device is instantaneous,
 - Time-delayed (R) if the downstream residual current device is selective (S).

The figure below shows how compliance with these rules provides discrimination on three levels: whatever the value of the fault current, it will be interrupted by the device situated immediately upstream of the fault and only by this device.

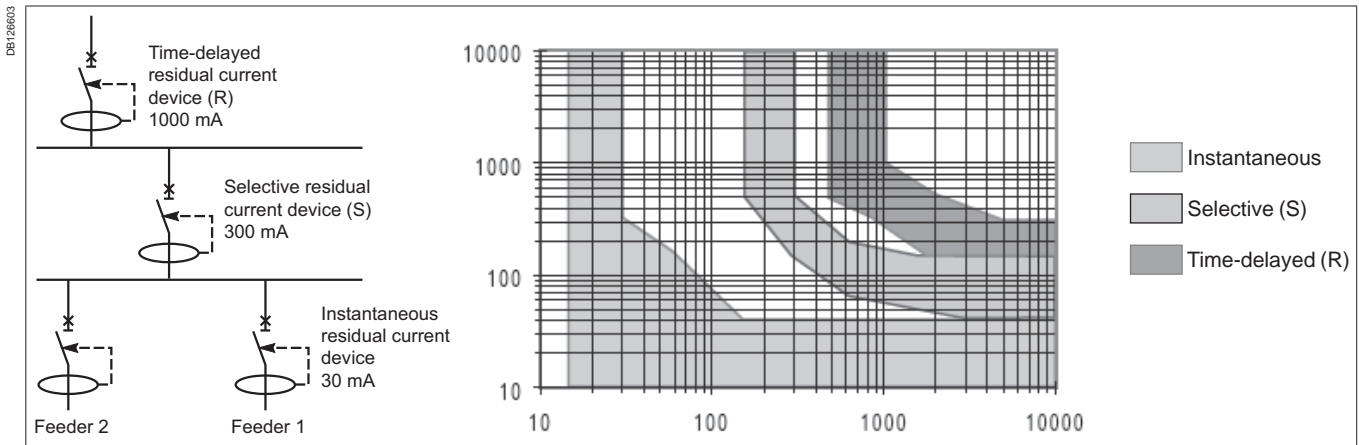

Example:

In the above diagram for a fault current of 1000 mA:

- if the fault occurs downstream of the 30 mA residual current device, the latter will interrupt the current in less than 40 ms, whereas type S and R devices "wait" for 80 ms and 200 ms respectively. Therefore, neither of the two devices trips.
- if the fault occurs downstream of the type S residual current device, the latter will interrupt the current in less than 175 ms, whereas the type R device "wait" for 200 ms and therefore does not trip.

If these cascading combination rules are complied with, the level of continuity of service provided to the user depends on the way in which the "horizontal discrimination" is implemented: the terminal feeders must be divided into as many circuits as necessary, each protected by a residual current device.

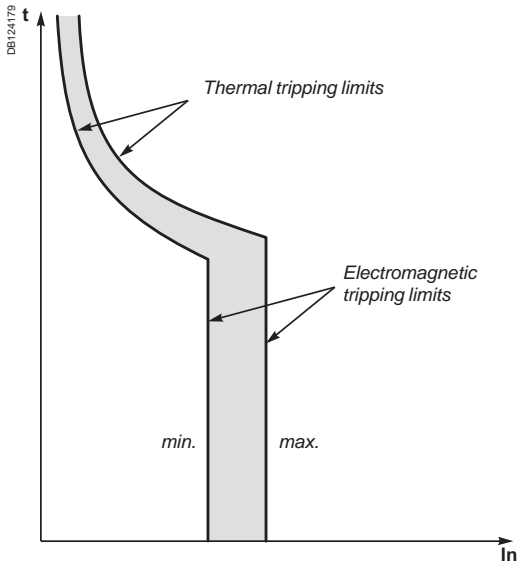

The following curves show the total fault current breaking time, depending on its amperage. For example: based on the curve on page 3, an iC60 circuit breaker of curve C, 20 A rating, will interrupt a current of 100 A (5 times the rated current I_n) in:

- 2 seconds at least
- 7 seconds at most.

The circuit breakers' tripping curves consist of two parts:

- tripping of overload protection (thermal tripping device): the higher the current, the shorter the tripping time
- tripping of short-circuit protection (magnetic tripping device): if the current exceeds the threshold of this protection device, the breaking time is less than 10 milliseconds. For short-circuit currents exceeding 20 times the rated current, the time-current curves do not give a sufficiently precise representation. The breaking of high short-circuit currents is characterized by the current limiting curves, in peak current and in energy. The total breaking time can be estimated at 5 times the value of the ratio $(I^2t)/(\hat{I})^2$.

Verification of the discrimination between two circuit breakers

By superimposing the curve of a circuit breaker on that of the circuit breaker installed upstream, one can check whether this combination will be discriminating in cases of overload (discrimination for all current values, up to the magnetic threshold of the upstream circuit breaker). This verification is useful when one of the two circuit breakers has adjustable thresholds; for fixed-threshold devices, this information is provided directly by the discrimination tables.

To check discrimination on short circuit, the energy characteristics of the two devices must be compared.

Tripping curves

According to IEC/EN 60898 standards

Alternative current 50/60 Hz

iC60a/N/H/L

According to IEC/EN 60898 (reference temperature 30°C)

Curves B, C, D rating up to 4 A

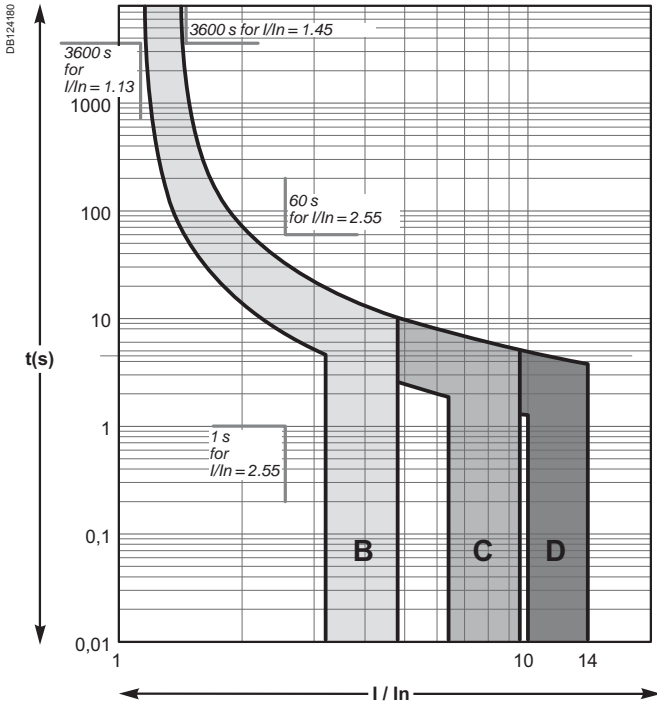

Curves B, C, D rating 6 A to 63 A

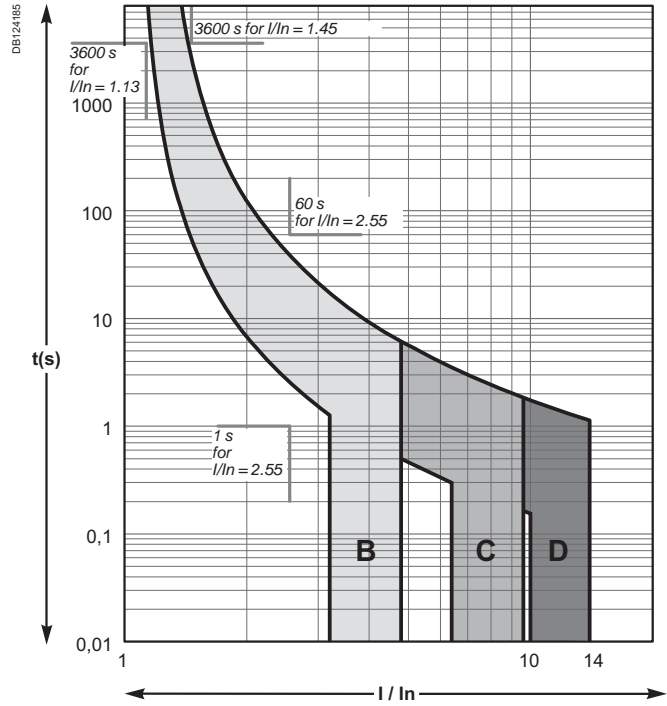

C120N/H

According to IEC/EN 60898 (reference temperature 30°C)

Curves B, C, D

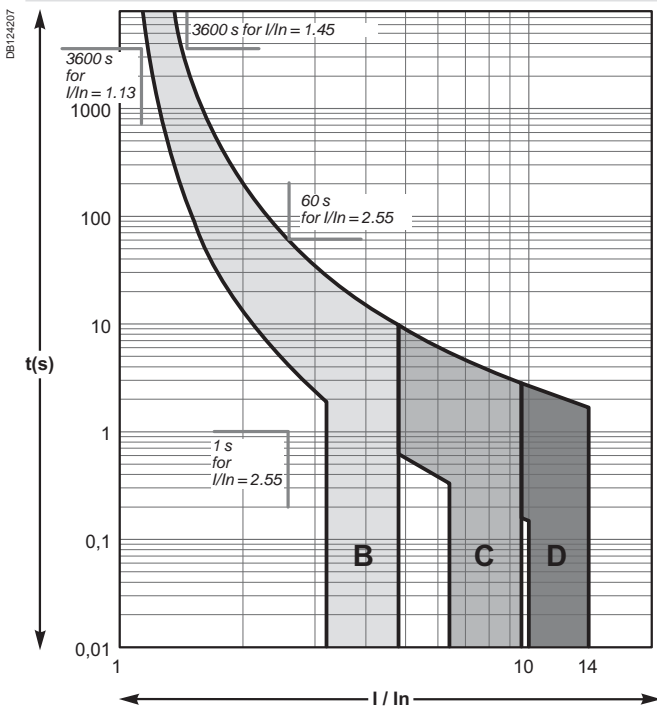

DPNa/N

According to IEC/EN 60898 (reference temperature 30°C)

Curves B, C, D

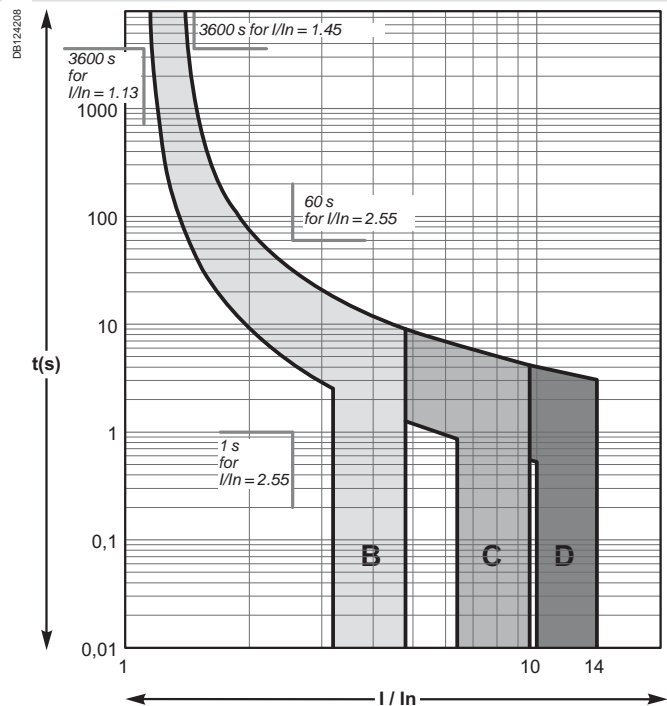

Alternative current 50/60 Hz

iK60

According to IEC/EN 60898 (reference temperature 30°C)

Curves B, C

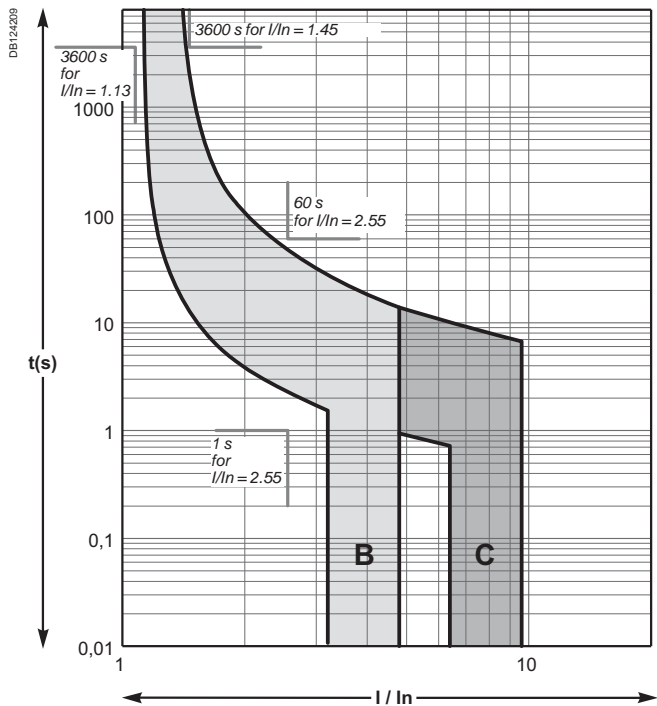

Tripping curves

According to IEC/EN 60947-2 standards

Alternative current 50/60 Hz

iC60N/H/L

According to IEC/EN 60947-2 (reference temperature 50°C)

Curves B, C, D rating up to 4 A

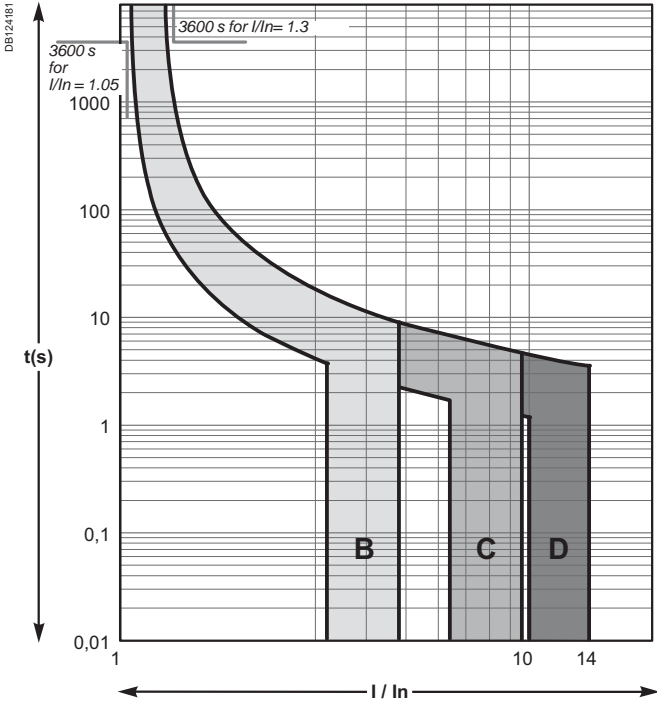

Curves Z, K rating up to 4 A

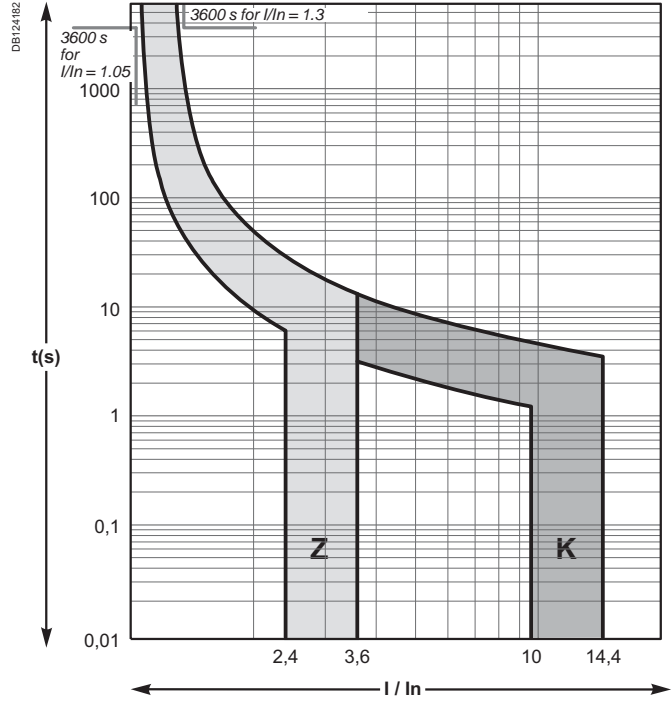

Curves B, C, D rating 6 A to 63 A

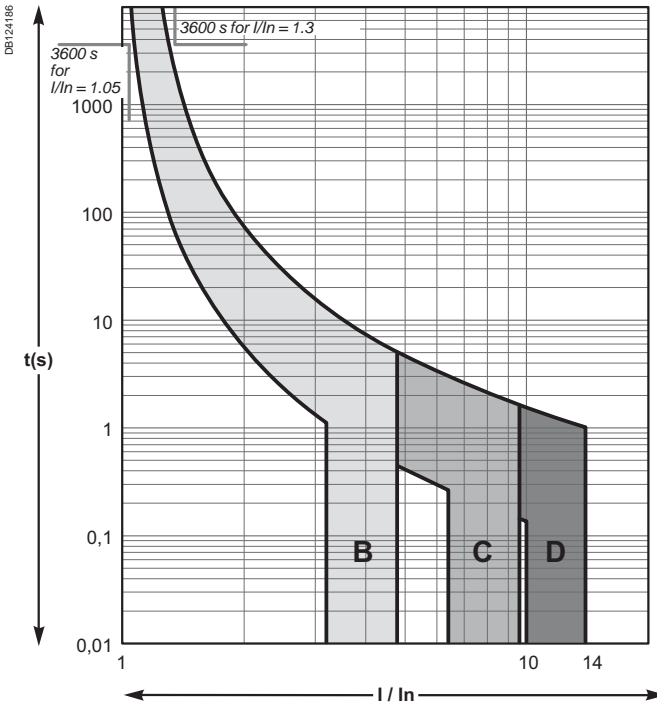

Curves Z, K rating 6 A to 63 A

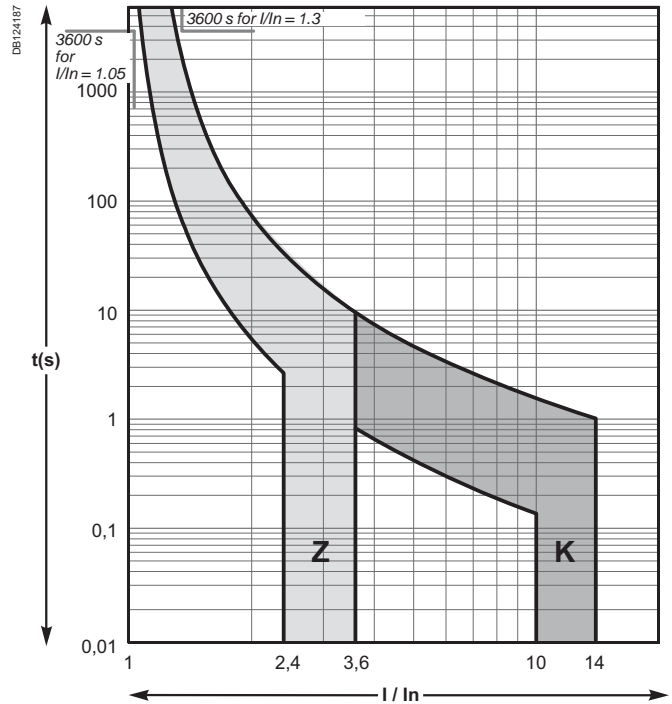

Tripping curves

According to IEC/EN 60947-2 standards

Alternative current 50/60 Hz

Reflex iC60N/H

According to IEC/EN 60947-2 (reference temperature 50°C)

Curves B, C, D

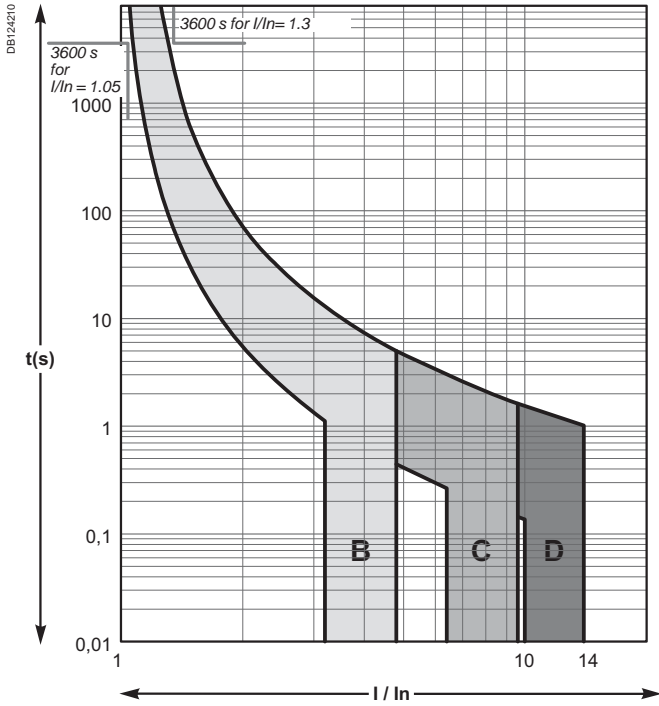

NG125a/N/H/L

According to IEC/EN 60947-2 (reference temperature 50°C)

Curves B, C, D

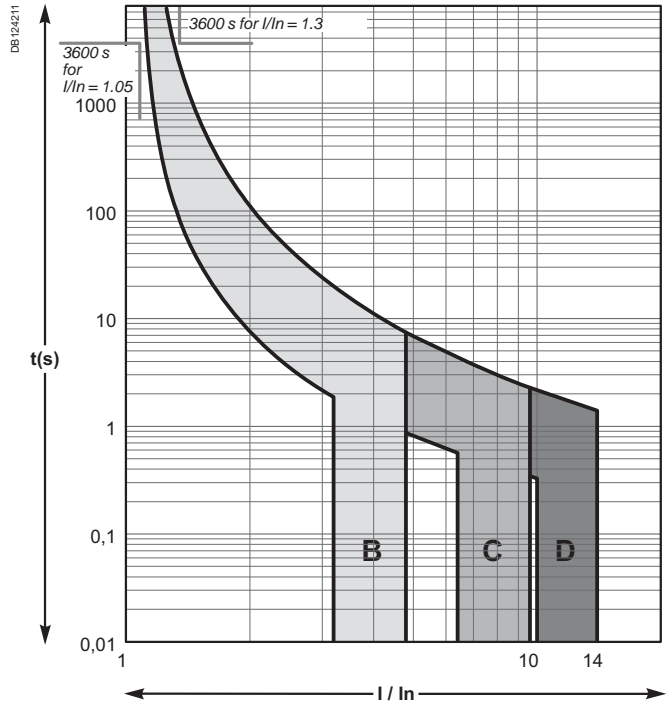

Tripping curves

According to IEC/EN 60947-2 standards

Motor curve

iC60L-MA
According to IEC/EN 60947-2

NG125L-MA
According to IEC/EN 60947-2 (reference temperature 50°C)

Curve MA

Curve MA

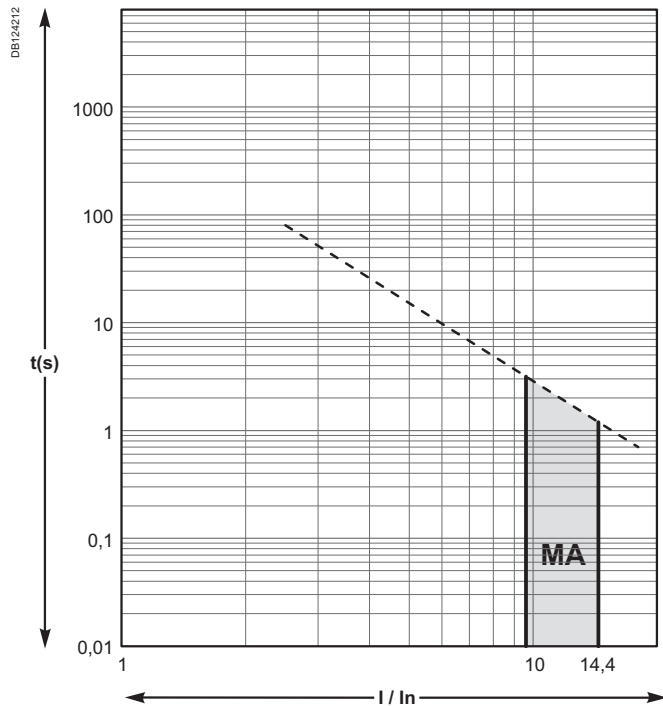
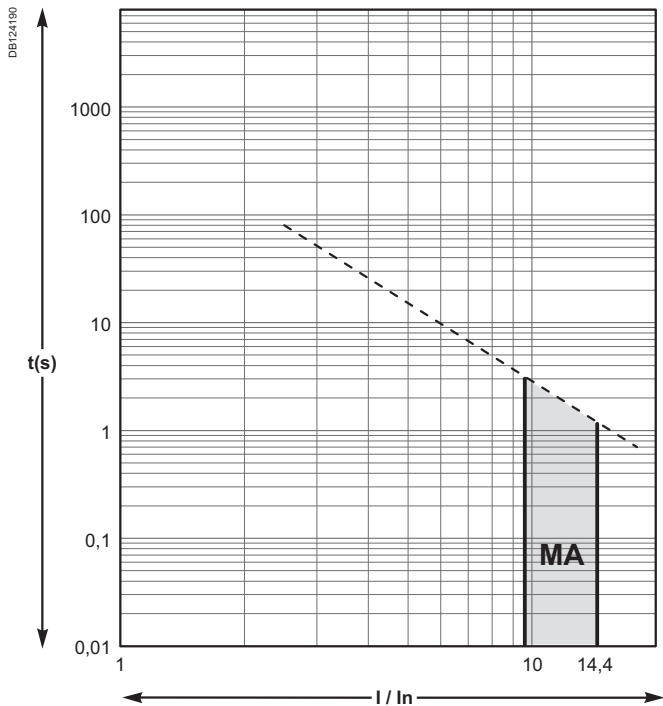

Tripping curves

According to IEC/EN 60947-2 standards

Direct current

iC60N/H/L

According to IEC/EN 60947-2 (reference temperature 50°C)

Curves B, C, D rating up to 4 A

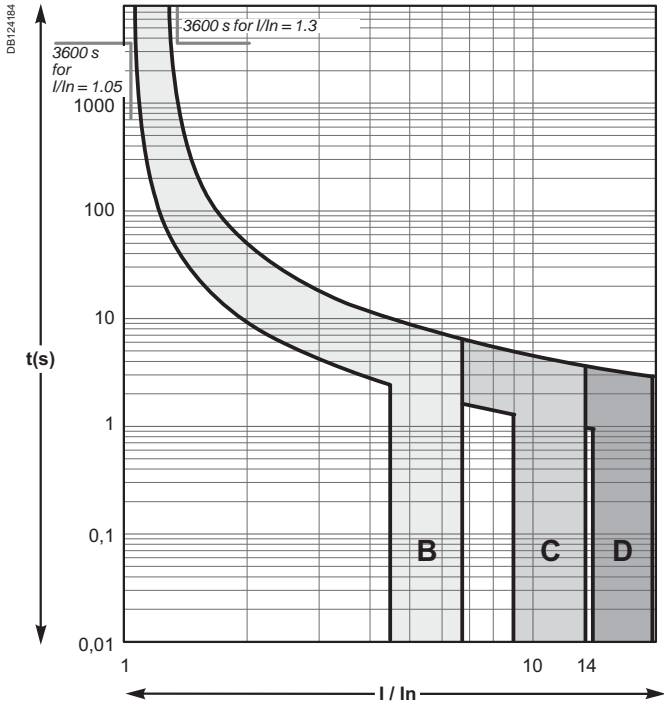

Curves Z, K rating up to 4 A

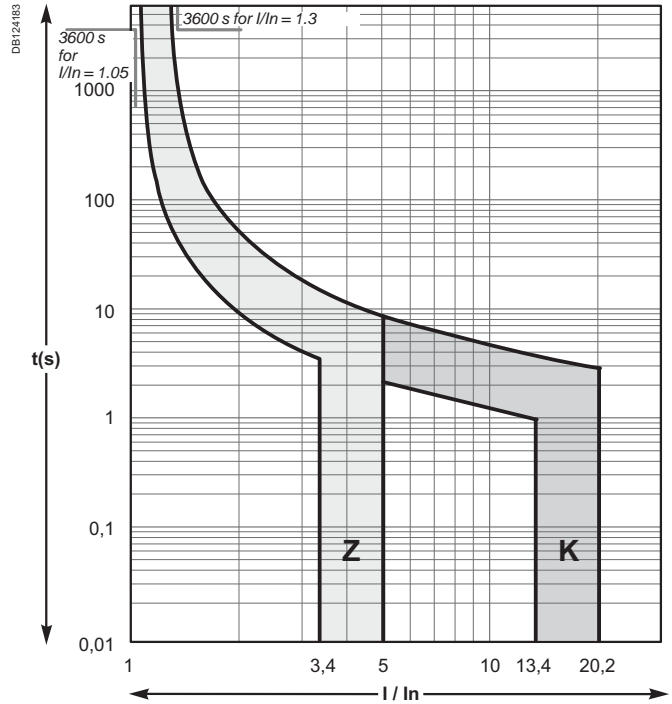

Curves B, C, D rating 6 A to 63 A

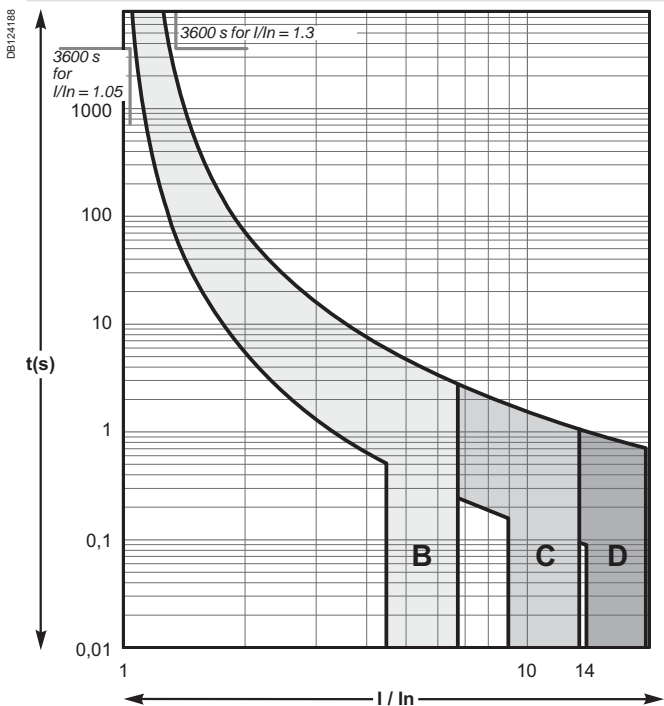

Curves Z, K rating 6 A to 63 A

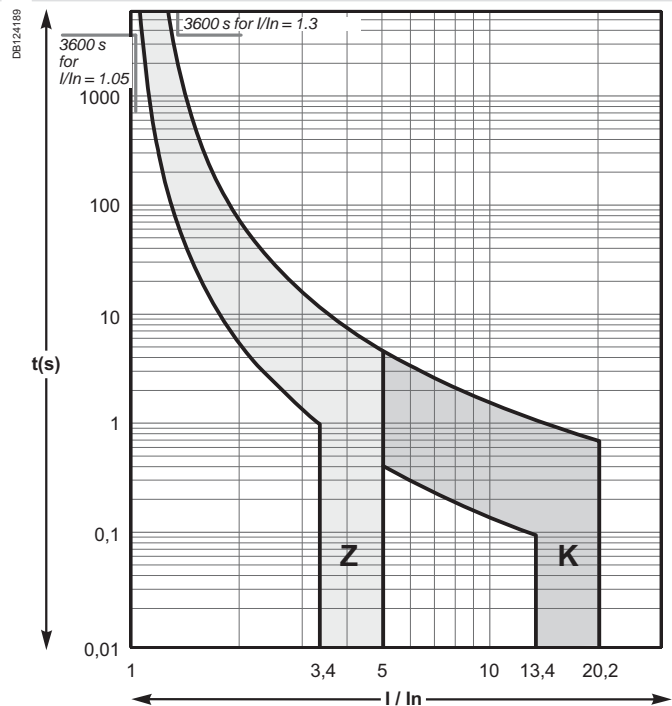

Direct current

C60H-DC

According to IEC/EN 60947-2 (reference temperature 25°C)

Curve C

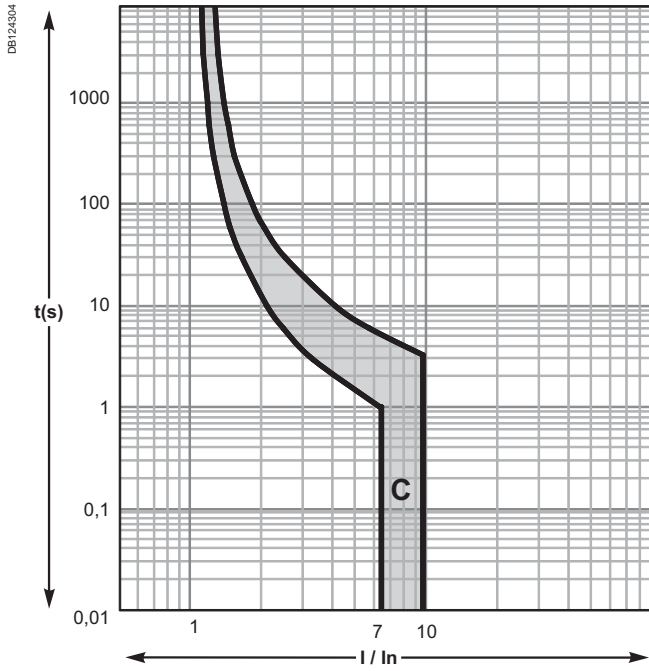

NG125a/N/H/L

According to IEC/EN 60947-2 (reference temperature 50°C)

Curves B, C, D

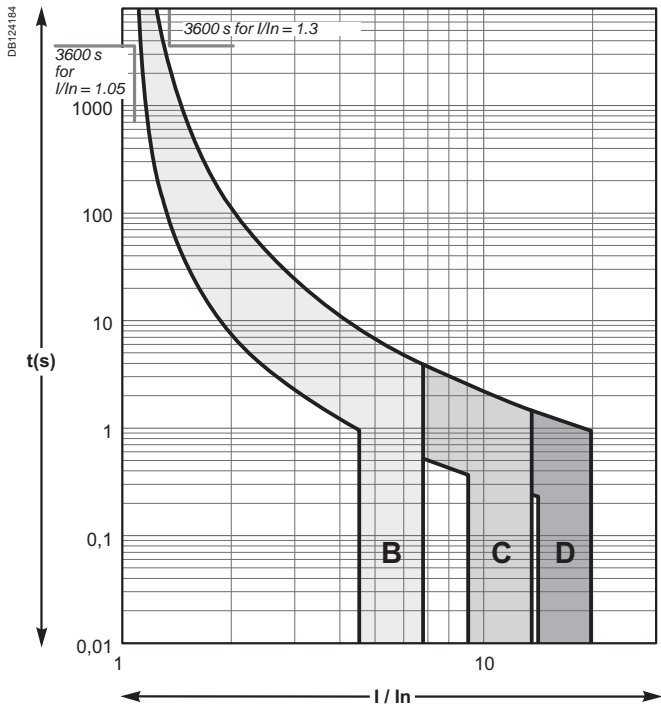

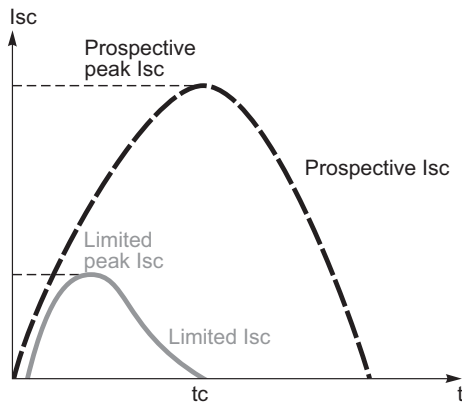

Prospective current and real limit current.

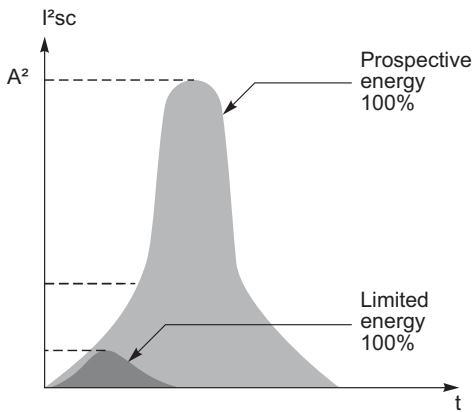

Definition

The limiting capacity of a circuit breaker is its ability to lessen the effects of a short circuit on an electrical installation by reducing the current amplitude and the dissipated power.

Benefits of limiting

Long installation service life

Thermal effects

Lower temperature rise at the conductor level, hence increased service life for cables and all components that are not self-protected (e.g. switches, contactors, etc.)

Mechanical effects

Lower electrodynamic repulsion forces, hence less risk of deformation or breakage of electrical contacts and busbars.

Electromagnetic effects

Less interference on sensitive equipment located in the vicinity of an electric circuit.

Savings through cascading

Cascading is a technique derived directly from current limiting: downstream of a current-limiting circuit breaker it is possible to use circuit breakers of breaking capacity lower than the prospective short-circuit current (in line with the cascading tables). The breaking capacity is heightened thanks to current limiting by the upstream device. Substantial savings can be achieved in this way on switchgear and enclosures.

Discrimination of protection devices

The circuit breakers' current limiting capacity improves discrimination with the protection devices located upstream: this is because the required energy passing through the upstream protection device is greatly reduced and can be not enough to cause it to trip. Discrimination can thus be natural without having to install a time-delayed protection device upstream.

Acti9 circuit breaker current limiting

Profiting from Schneider Electric's experience and expertise in the field of short-circuit current breaking, the circuit breakers of the Acti9 range have a top-level current limiting characteristic for modular devices.

This assures them of optimal protection of the entire power distribution system.

Short-circuit current limiting (cont.)

Representation: Current limiting curves

The current limiting capacity of a circuit breaker is reflected by 2 curves which give, as a function of the prospective short-circuit current (current which would flow in the absence of a protection device):

- the real peak current (limited)
- the thermal stress (in A²s), this value, multiplied by the resistance of any element through which the short-circuit current passes, gives the power dissipated by this element.

The straight line "10 ms" representing the energy A²s of a prospective short-circuit current of a half-period (10 ms) indicates the energy that would be dissipated by the short-circuit current in the absence of limiting by the protection device (see example).

Example

What is the energy limited by an iC60N 25 A circuit breaker for a prospective short-circuit current of 10 kA rms. What is the quality of current limiting?

> as shown in the graph opposite:

- this short-circuit current (10 kA rms) is likely to dissipate up to 1,000 kA²s
- the iC60N circuit breaker reduces this thermal stress to: 45 kA²s, which is 22 times less.

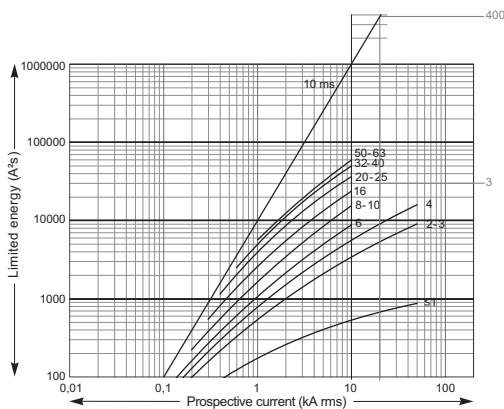

Example of use: Stresses acceptable by the cables

The following table shows the thermal stresses acceptable by the cables depending on their insulation, their composition (Cu or Al) and their cross section. Cross-section values are expressed in mm² and stresses in A²s.

S (mm ²)		1.5	2.5	4	6	10
PVC	Cu	2.97 x 10 ⁴	8.26 x 10 ⁴	2.12 x 10 ⁵	4.76 x 10 ⁵	1.32 x 10 ⁶
	Al					5.41 x 10 ⁵
PRC	Cu	4.10 x 10 ⁴	1.39 x 10 ⁵	2.92 x 10 ⁵	6.56 x 10 ⁵	1.82 x 10 ⁶
	Al					7.52 x 10 ⁵
S (mm ²)		16	25	35	50	
PVC	Cu	3.4 x 10 ⁶	8.26 x 10 ⁶	1.62 x 10 ⁷	3.21 x 10 ⁷	
	Al	1.39 x 10 ⁶	3.38 x 10 ⁶	6.64 x 10 ⁶	1.35 x 10 ⁷	
PRC	Cu	4.69 x 10 ⁶	1.39 x 10 ⁷	2.23 x 10 ⁷	4.56 x 10 ⁷	
	Al	1.93 x 10 ⁶	4.70 x 10 ⁶	9.23 x 10 ⁶	1.88 x 10 ⁷	

Example

Is a Cu/PVC cable of cross section 10 mm² protected by a NG125L device?

The above table shows that the acceptable stress is 1.32 x 10⁶ A²s. Any short-circuit current at the point where a NG125L device (I_{cu} = 25 kA) is installed will be limited, with a thermal stress of less than 2.2 x 10⁵ A²s. (Curve on page <?> - <?>).

The cable is therefore always protected up to the breaking capacity of the circuit breaker.

Short-circuit current limiting (cont.)

Limitation curves for 240 V network

iDPN

1P+N / 3P / 3P+N circuit breakers

Peak current

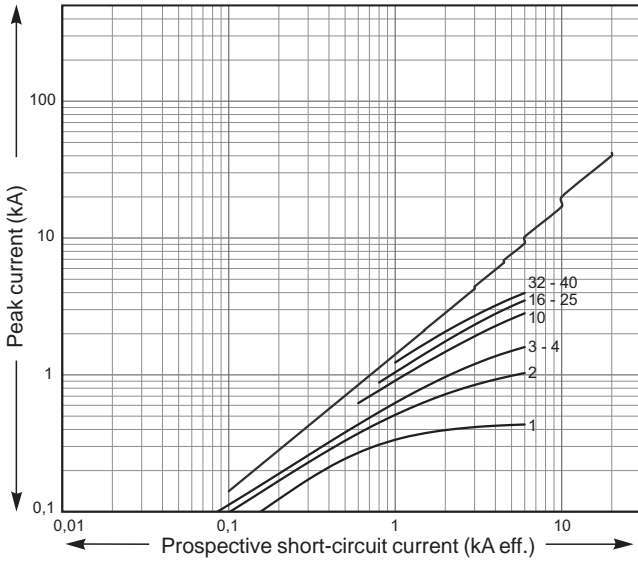

Thermal stress

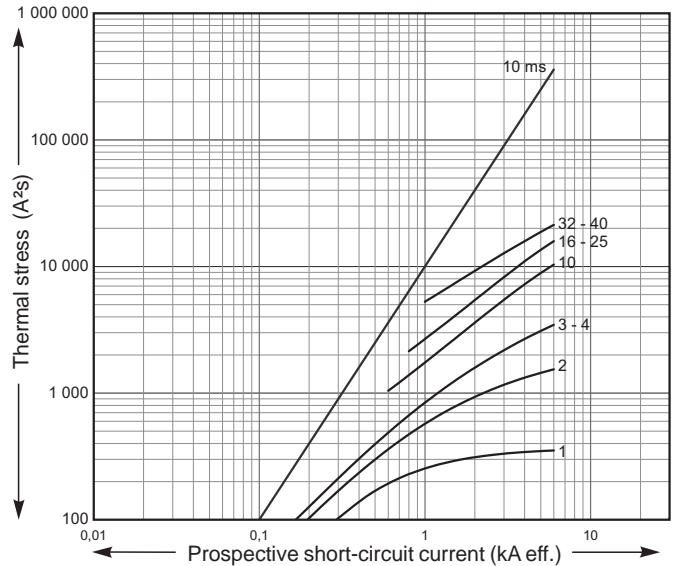

iDPN N

1P+N / 3P / 3P+N circuit breakers

Peak current

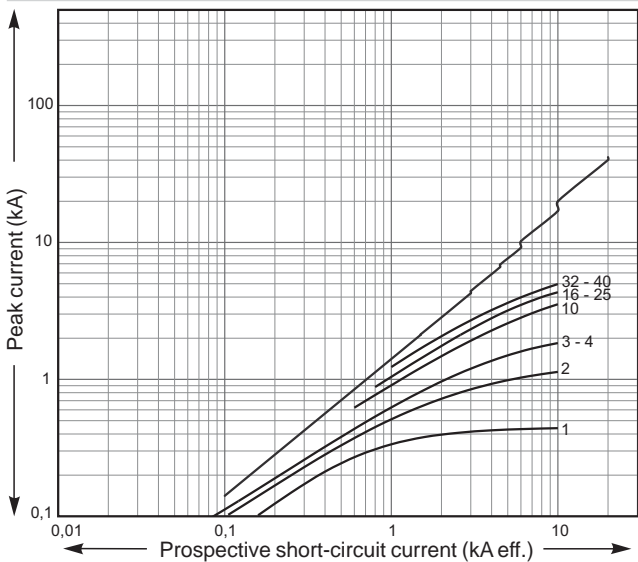

Thermal stress

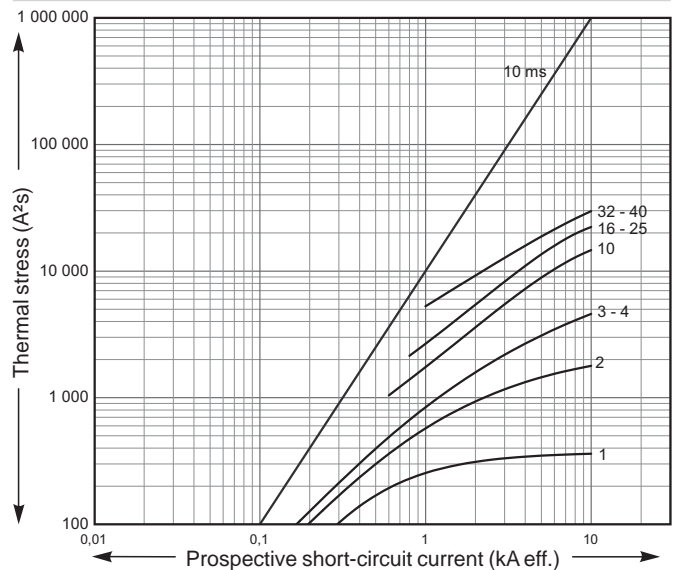

Short-circuit current limiting (cont.)

Limitation curves for 415 V network

iDPN

1P+N / 3P / 3P+N circuit breakers

Peak current

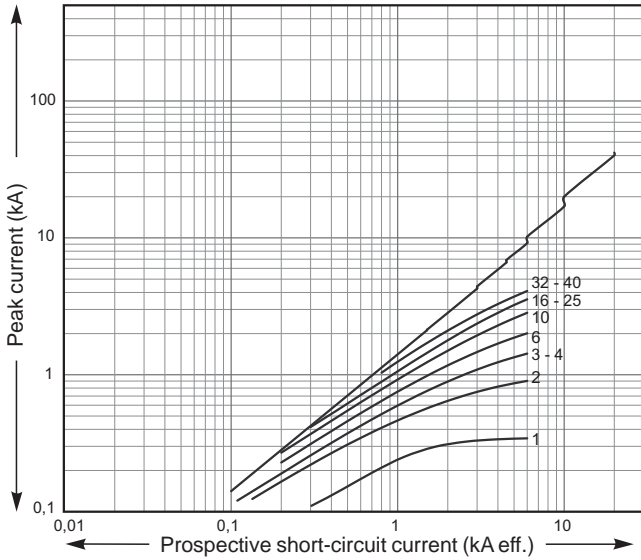

Thermal stress

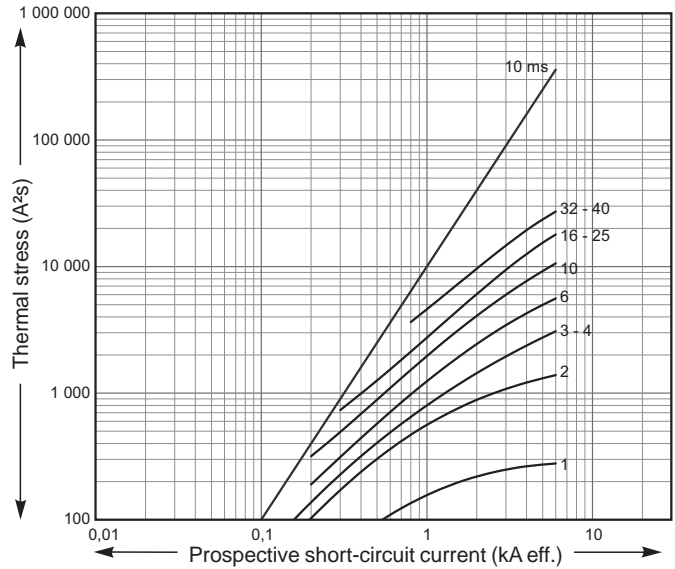

iDPN N

1P+N / 3P / 3P+N circuit breakers

Peak current

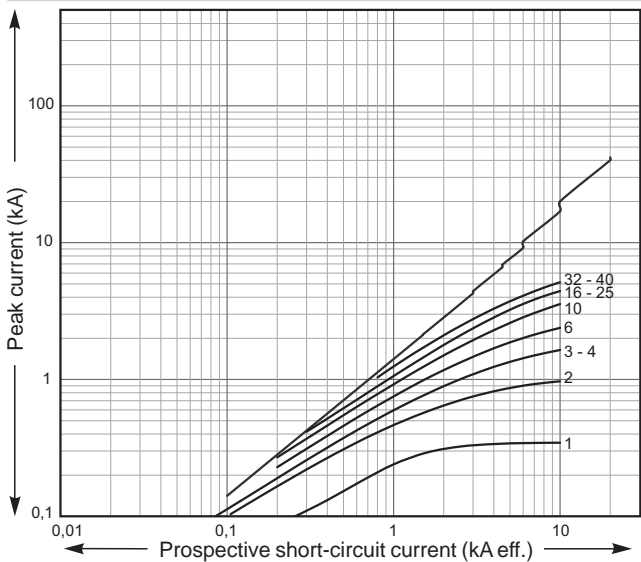

Thermal stress

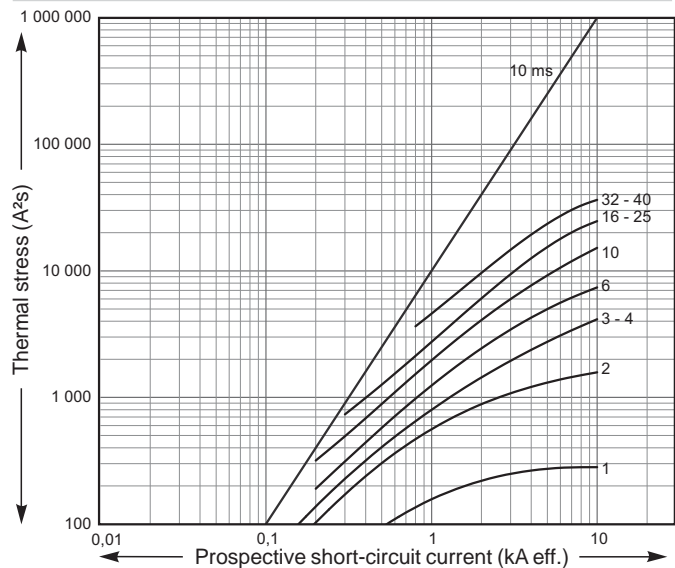

Short-circuit current limiting (cont.)

Limitation curves for 240 V network

iK60N 2P curve B

2P circuit breaker
Peak current

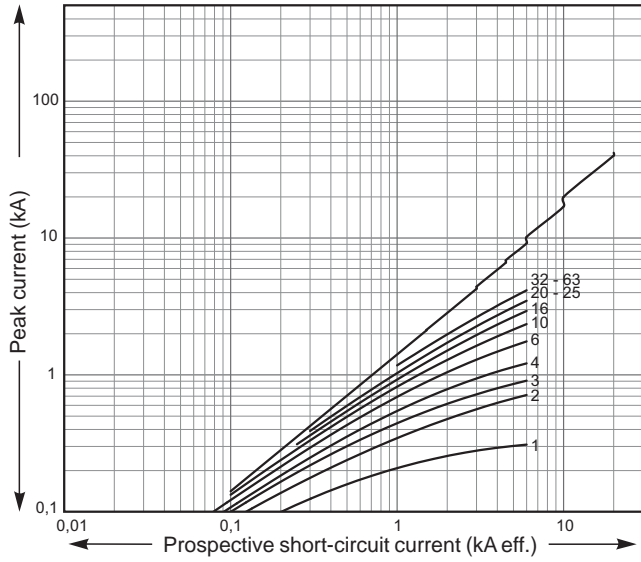

Thermal stress

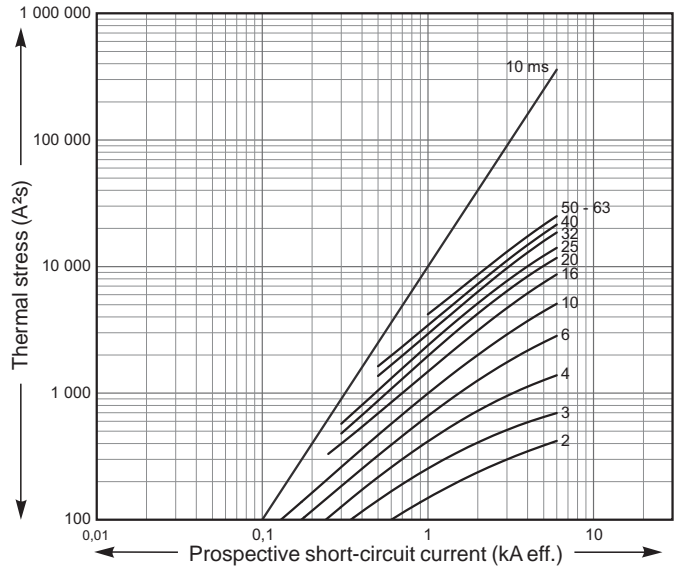

iK60N 2P curve C

2P circuit breaker
Peak current

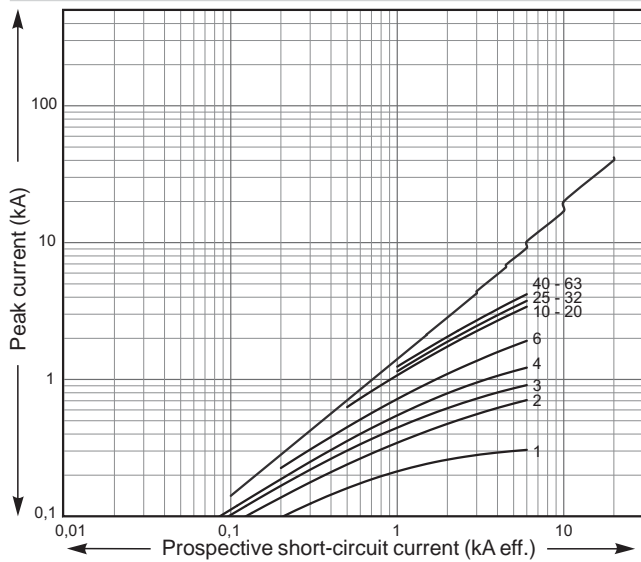

Thermal stress

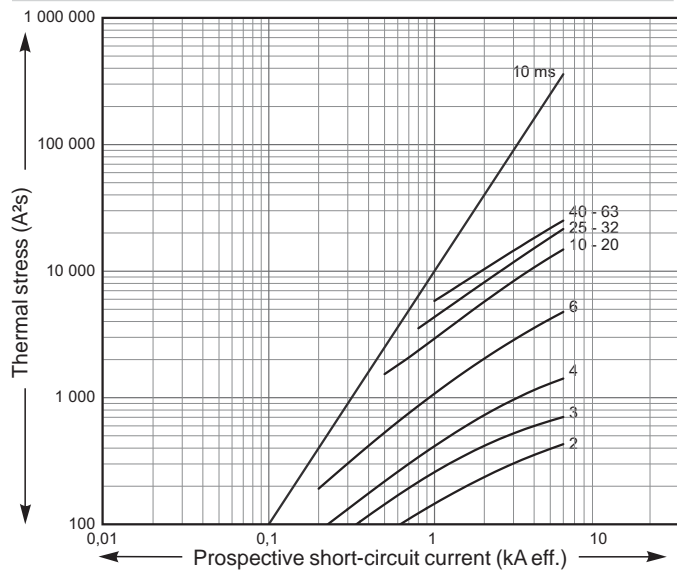

Short-circuit current limiting (cont.)

Limitation curves for 415 V network

iK60N 3P curve B

2P / 3P / 4P circuit breakers
Peak current

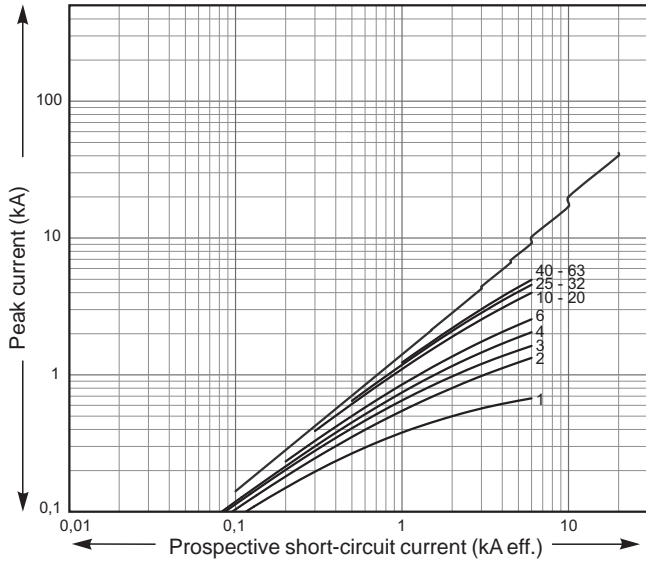

Thermal stress

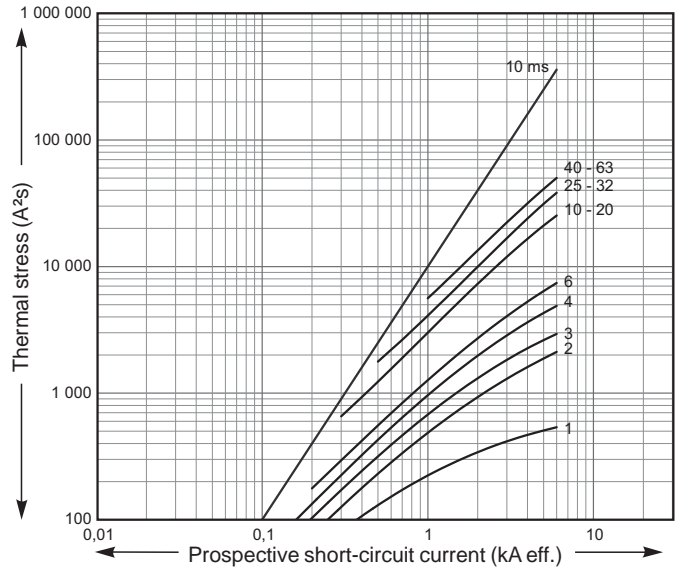

iK60N 3P curve C

2P / 3P / 4P circuit breakers
Peak current

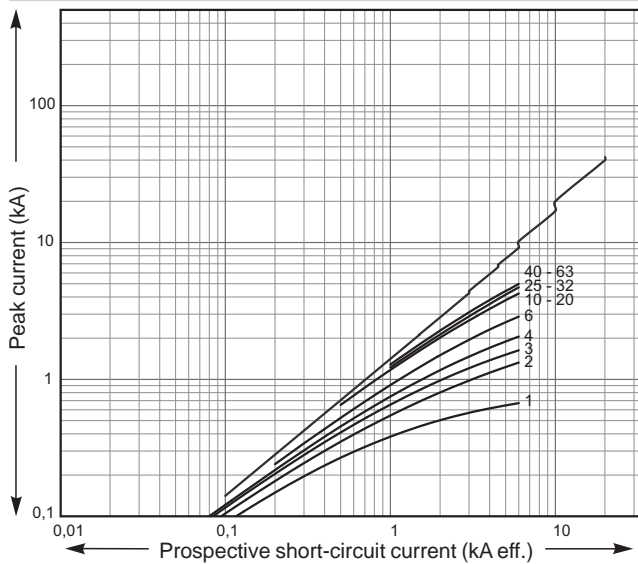

Thermal stress

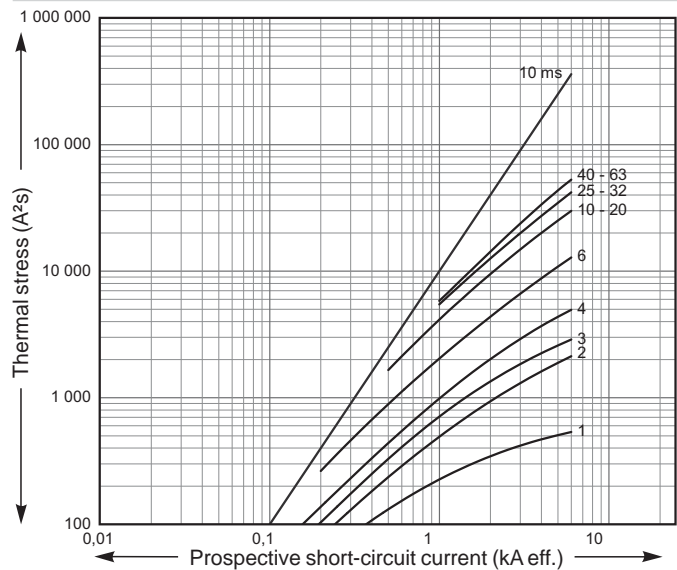

Short-circuit current limiting (cont.)

Limitation curves for 230 V single-phase or 400 V three-phase network (TN or TT earthing system)

iC60N

1P / 3P / 4P circuit breakers
Peak current

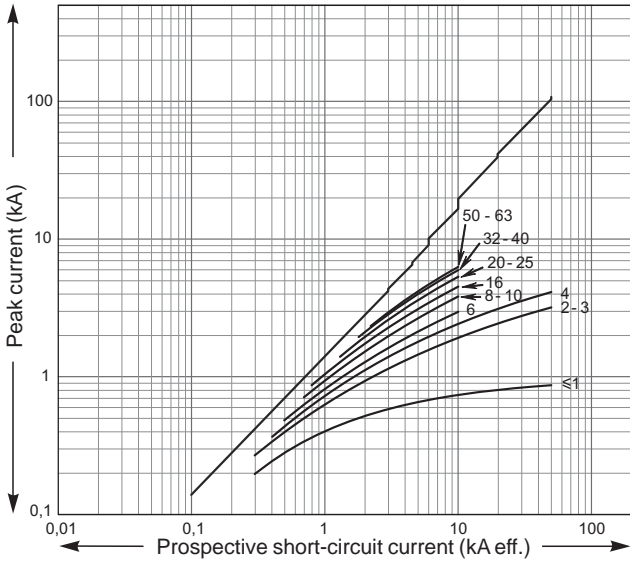

Thermal stress

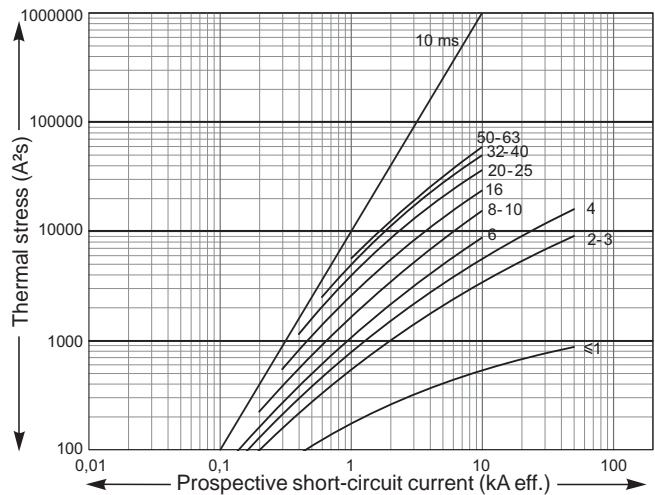

1P+N / 2P circuit breakers
Peak current

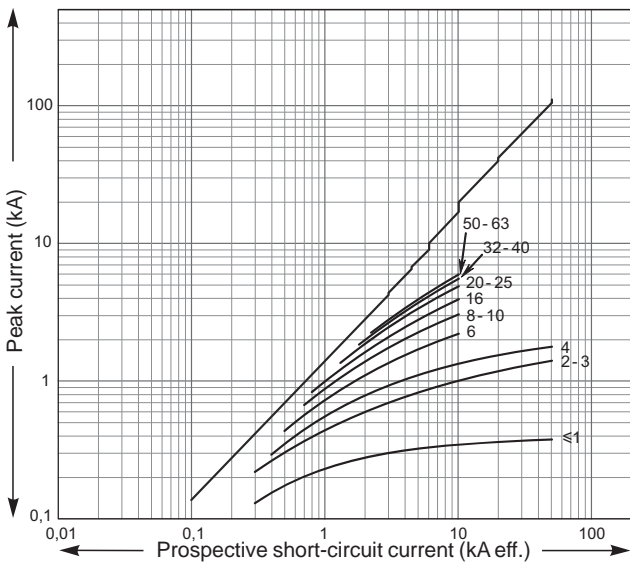

Thermal stress

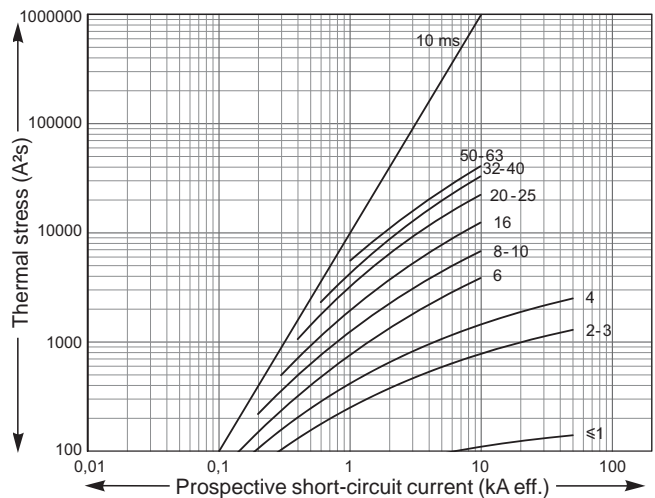

Note: these values are also the limitation values obtained with an iC60N three- or four-pole circuit breaker operating on a 230 V phase-to-phase network.

Short-circuit current limiting (cont.)

iC60H

1P / 3P / 4P circuit breakers

Peak current

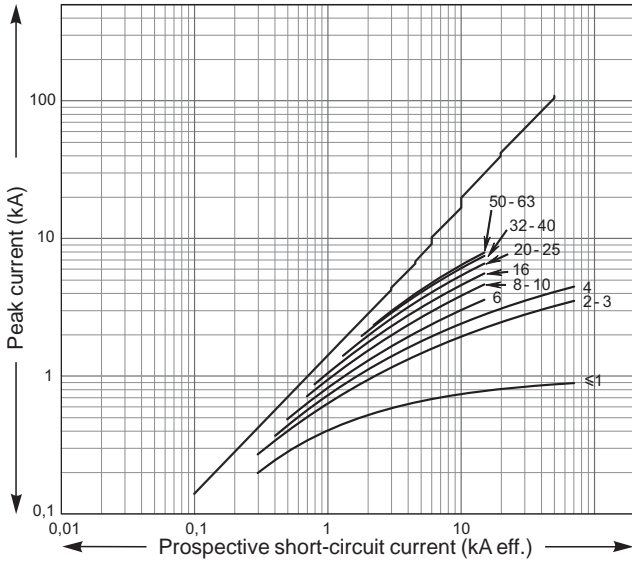

Thermal stress

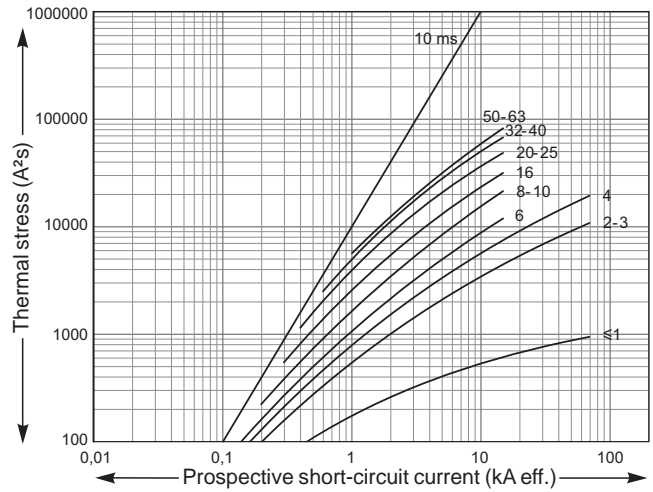

1P+N / 2P circuit breakers

Peak current

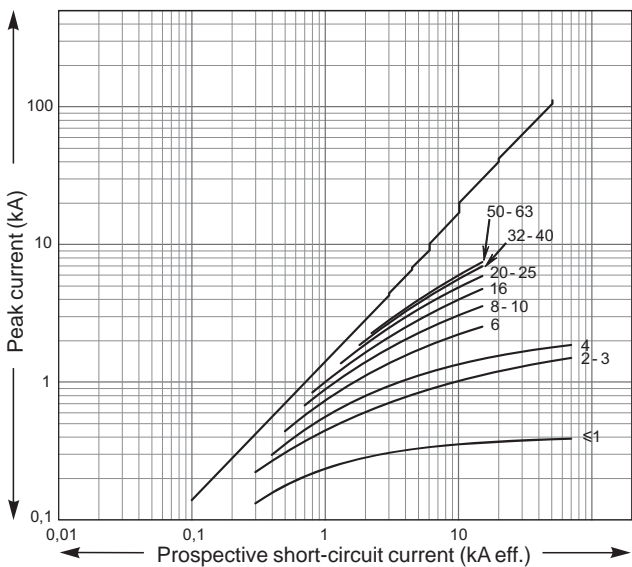

Thermal stress

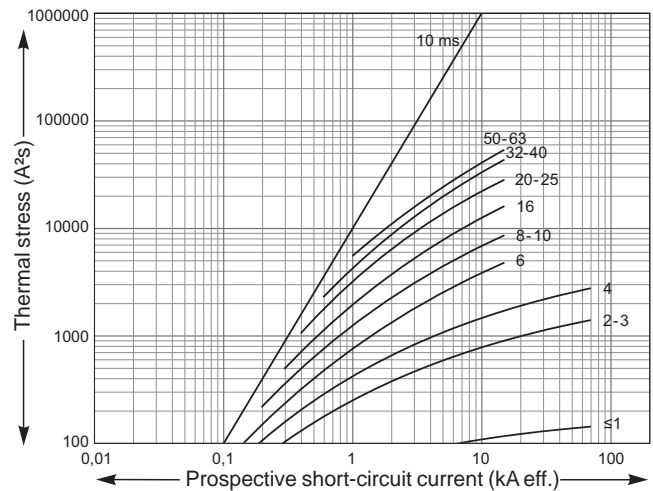

Note: these values are also the limitation values obtained with an iC60H three- or four-pole circuit breaker operating on a 230 V phase-to-phase network.

Short-circuit current limiting (cont.)

iC60L

1P / 3P / 4P circuit breakers

Peak current

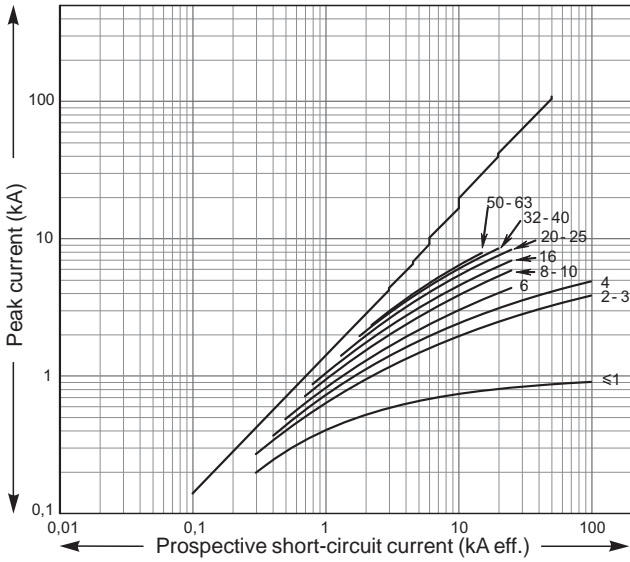

Thermal stress

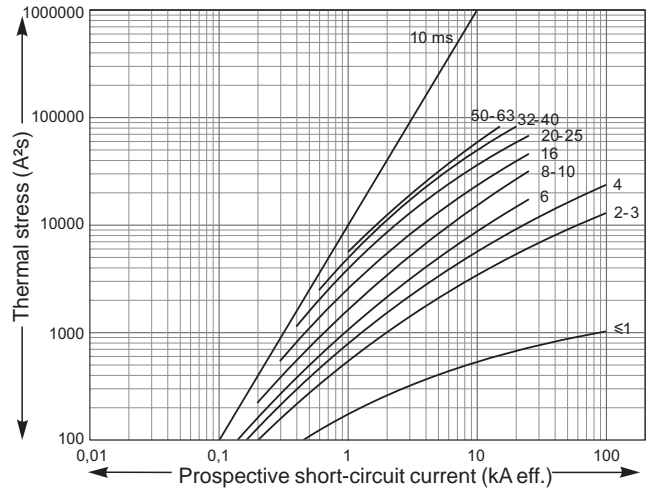

1P+N / 2P circuit breakers

Peak current

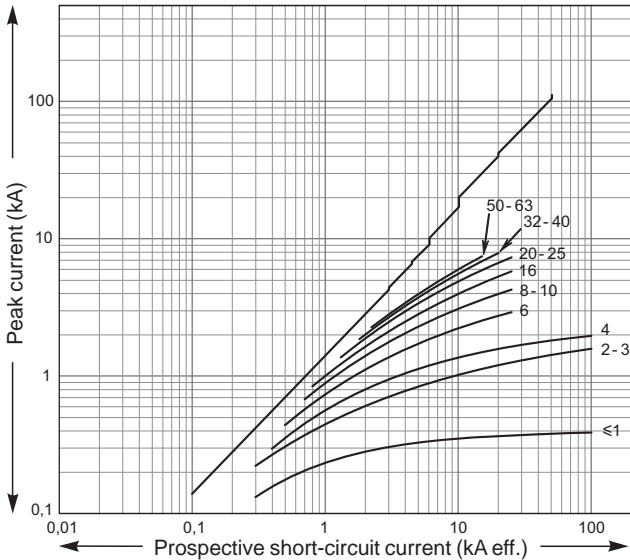

Thermal stress

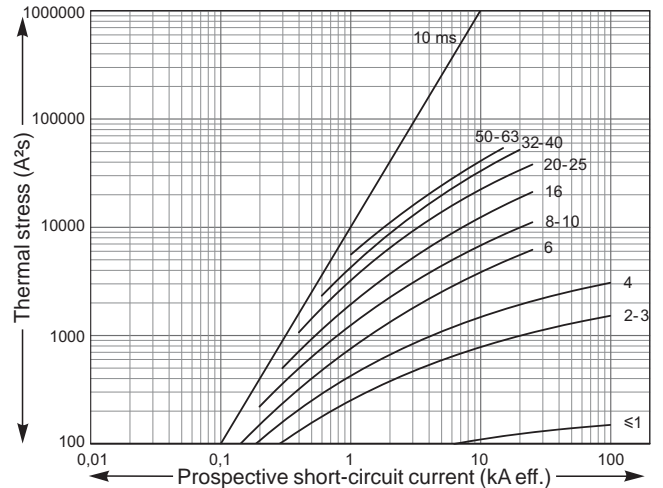

Note: these values are also the limitation values obtained with an iC60L three- or four-pole circuit breaker operating on a 230 V phase-to-phase network.

Short-circuit current limiting (cont.)

Limitation curves for 220/440 V network

C60H-DC curve C

Circuit-breakers: 1P (220 V) - 2P (440 V)
Peak current

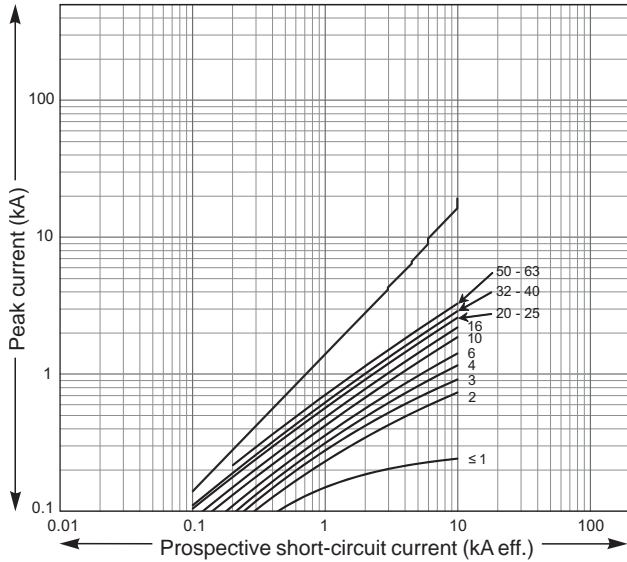

Thermal stress

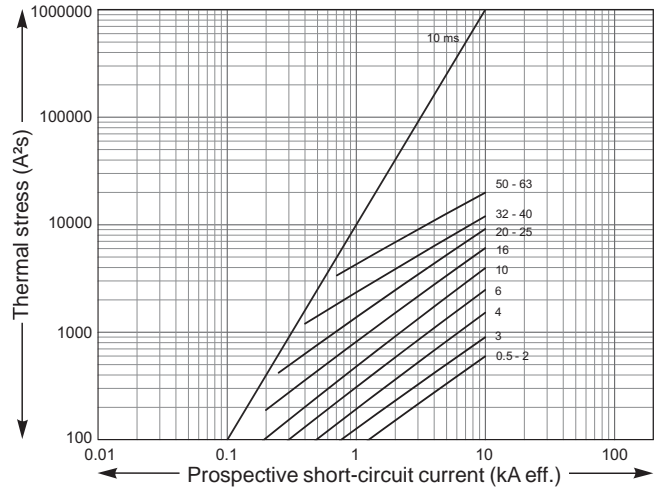

Circuit-breakers: 1P (250 V) - 2P (500 V)
Peak current

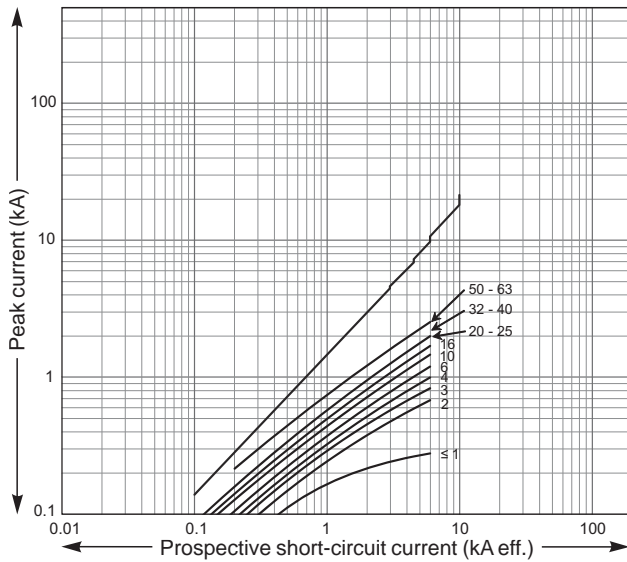

Thermal stress

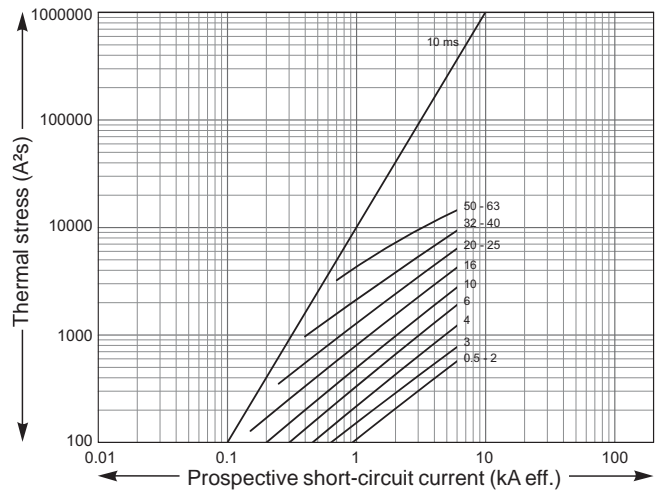

Short-circuit current limiting (cont.)

Limitation curves for 240 V network

C120N, H curve C

2P / 3P / 4P circuit-breakers Peak current

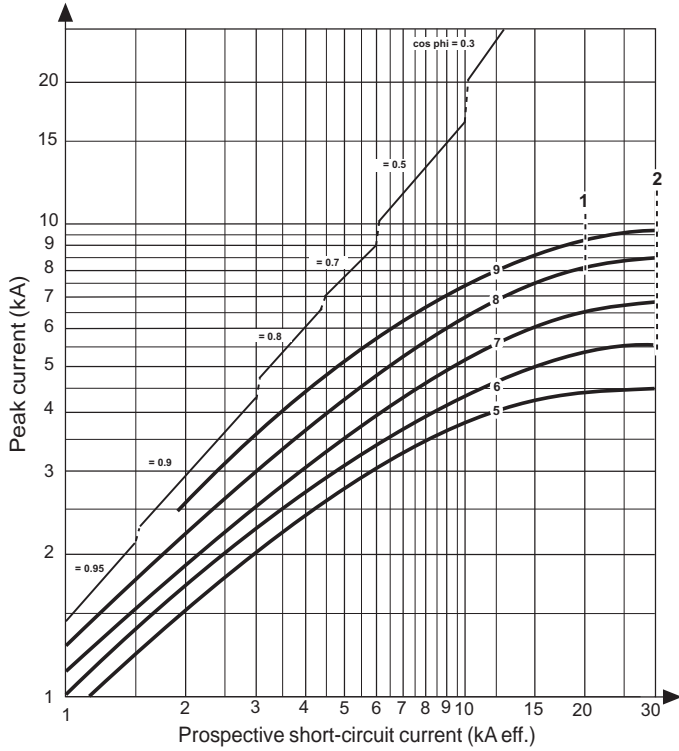

- Circuit breaker type in accordance with the mark:
- 1: C120N,
- 2: C120H,
- 5: 10-16 A,
- 6: 20-25 A,
- 7: 32-40 A,
- 8: 50-63 A,
- 9: 80-100-125 A.

2P / 3P / 4P circuit-breakers Thermal stress

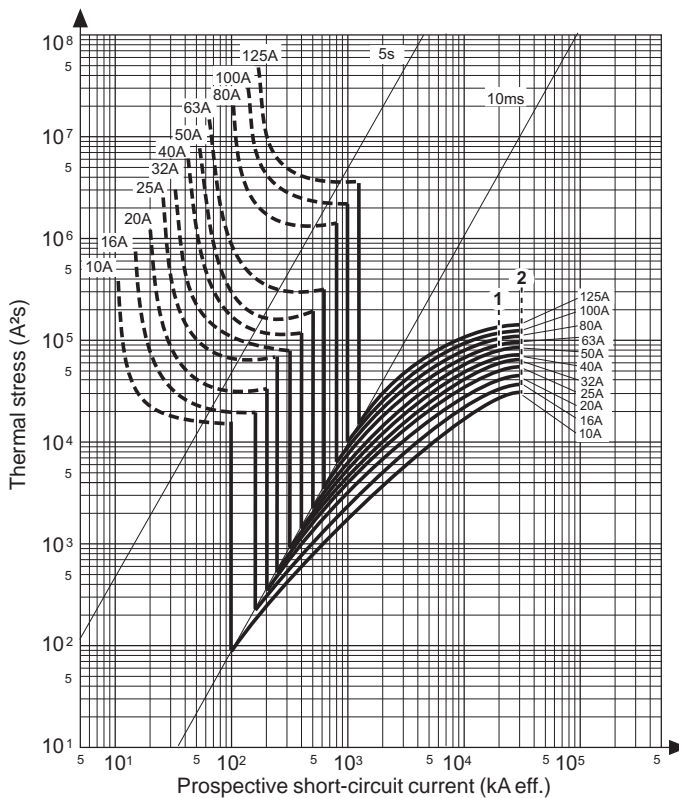

- Circuit breaker type in accordance with the mark:
- 1: C120N,
- 2: C120H.

Short-circuit current limiting (cont.)

Limitation curves for 240/415 V network

C120N, H curve C

Circuit-breakers: 1P (240 V) - 2P / 3P / 4P (415 V)
Peak current

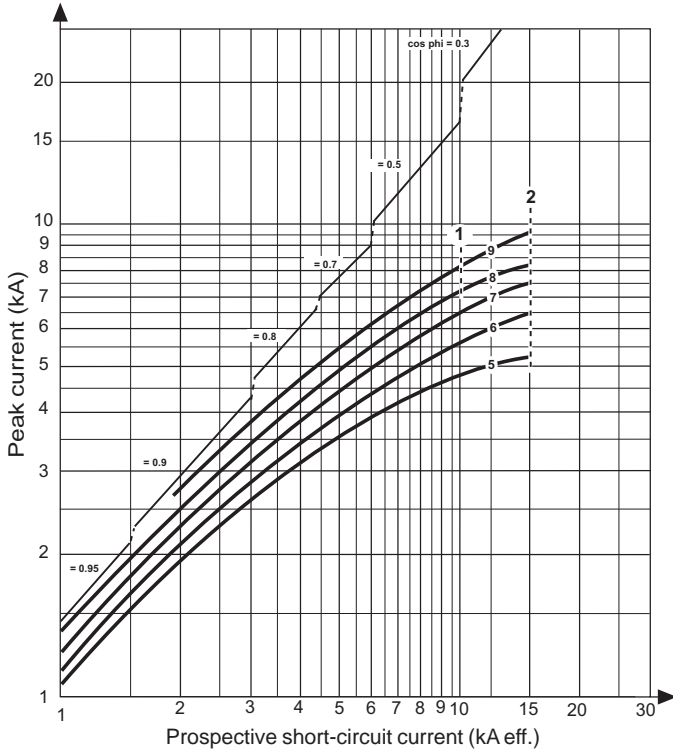

- Circuit breaker type in accordance with the mark:
- 1: C120N,
- 2: C120H,
- 5: 10-16 A,
- 6: 20-25 A,
- 7: 32-40 A,
- 8: 50-63 A,
- 9: 80-100-125 A.

Circuit-breakers: 1P (240 V) - 2P / 3P / 4P (415 V)
Thermal stress

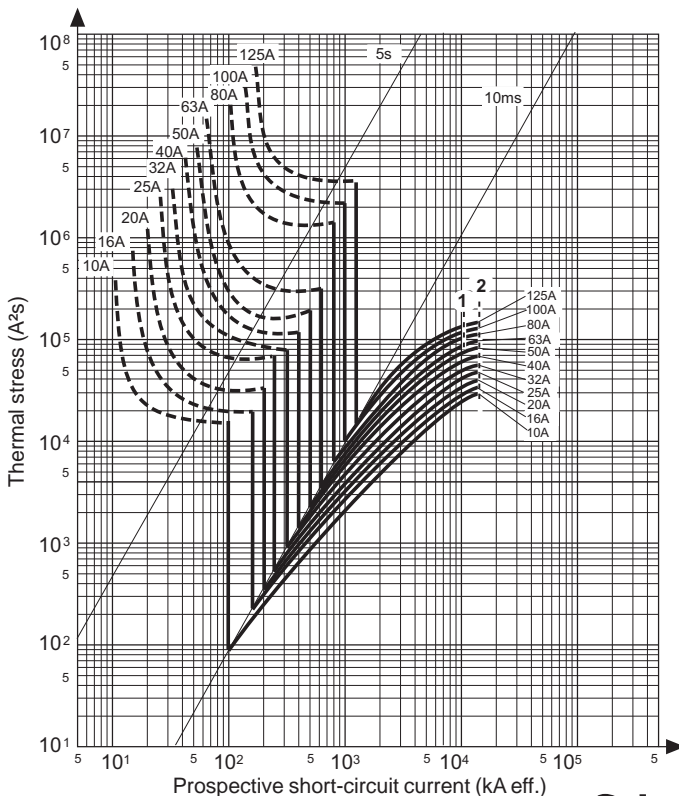

- Circuit breaker type in accordance with the mark:
- 1: C120N,
- 2: C120H.

Limitation curves for 440 V network

C120N, H curve C

2P / 3P / 4P circuit-breakers

Peak current

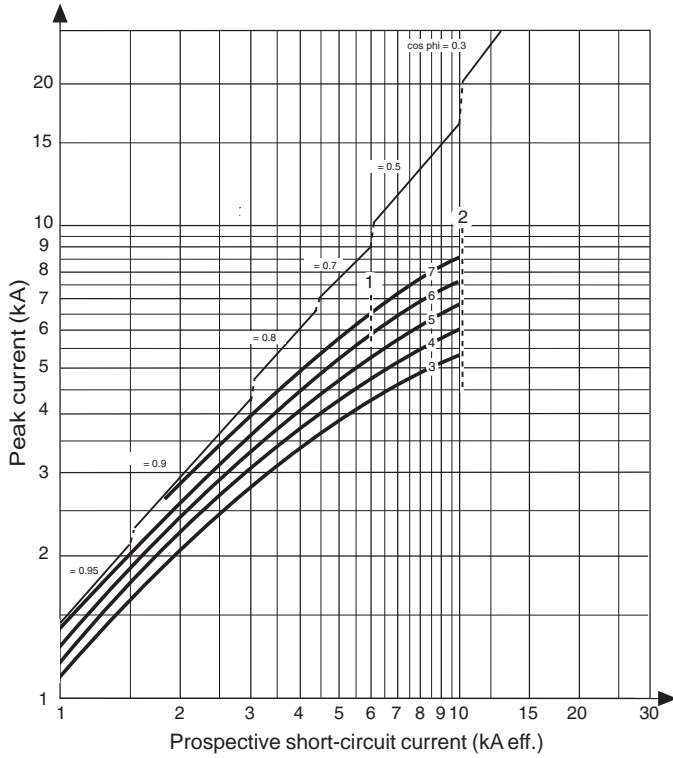

- Circuit breaker type in accordance with the mark:
- 1: C120N calibres 63 à 125 A,
- 2: C120H calibres 10 à 125 A.

2P / 3P / 4P circuit-breakers

Thermal stress

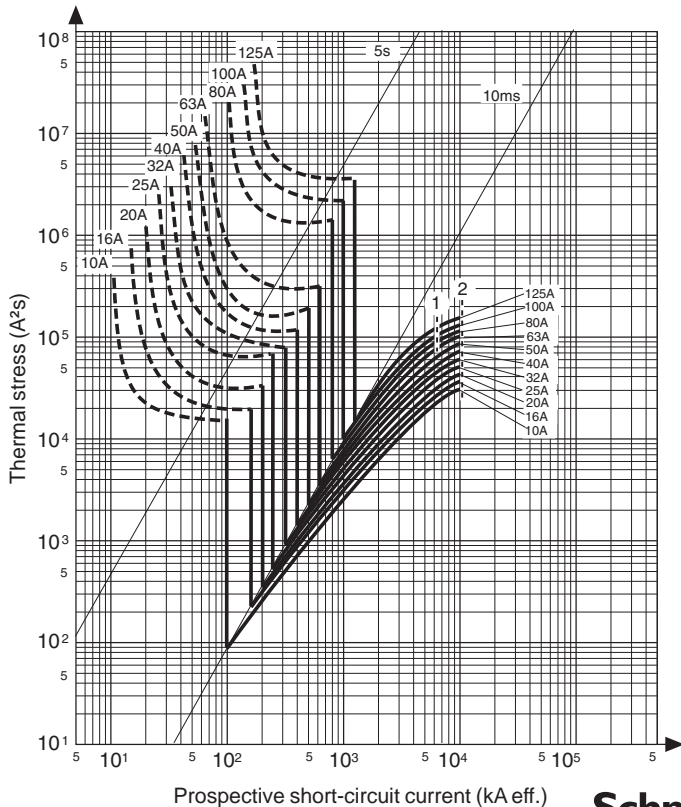

- Circuit breaker type in accordance with the mark:
- 1: C120N,
- 2: C120H.

Short-circuit current limiting (cont.)

Limitation curves for 240 V network

NG125a, N, H, L curve C

2P / 3P / 4P circuit-breakers Peak current

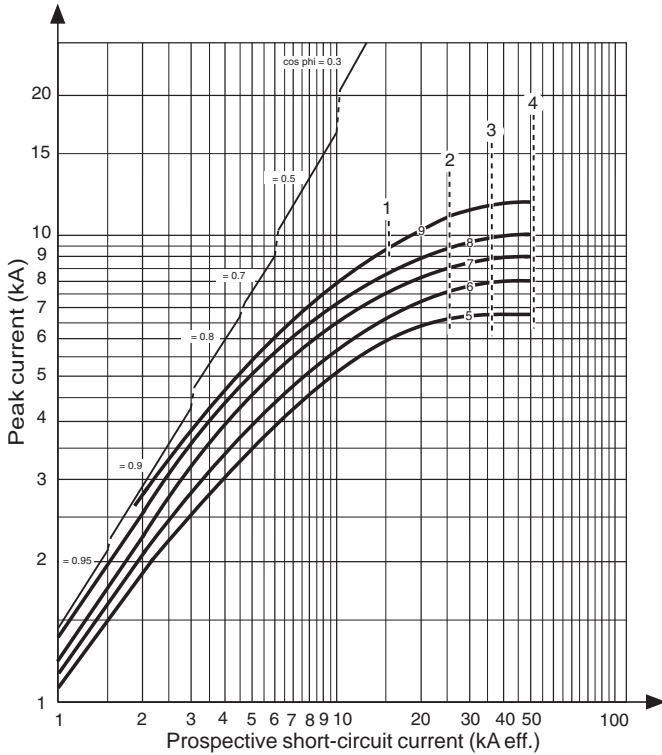

■ Circuit breaker type in accordance with the mark:

- 1: NG125a,
- 2: NG125N,
- 3: NG125H,
- 4: NG125L,
- 5: 10-16 A,
- 6: 20-25 A,
- 7: 32-40 A,
- 8: 50-63 A,
- 9: 80-100-125 A.

2P / 3P / 4P circuit-breakers Thermal stress

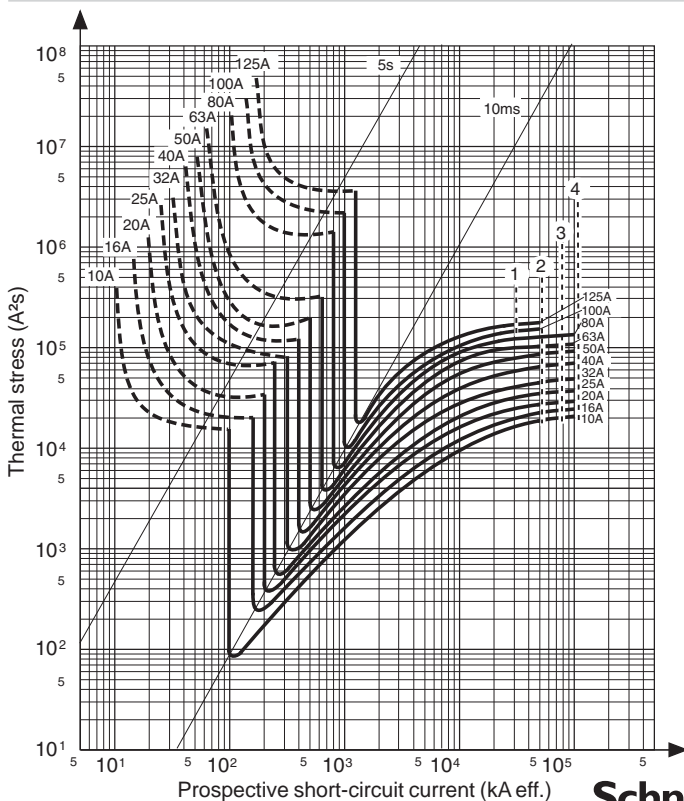

■ Circuit breaker type in accordance with the mark:

- 1: NG125a 80-100-125 A,
- 2: NG125N,
- 3: NG125H,
- 4: NG125L.

Limitation curves for 240/415 V network

NG125a, N, H, L curve C

Circuit-breakers: 1P (240 V) - 2P / 3P / 4P (415 V)
Peak current

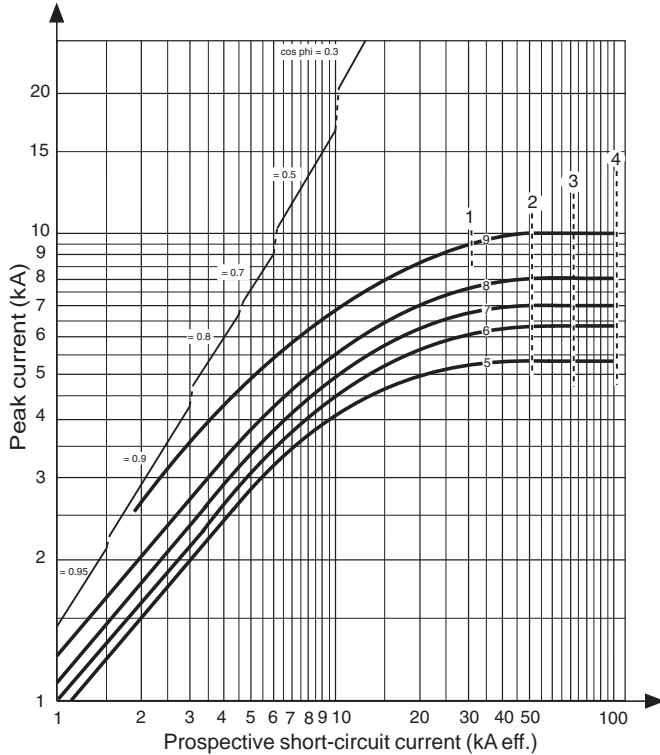

■ Circuit breaker type in accordance with the mark:

- 1: NG125a,
- 2: NG125N,
- 3: NG125H,
- 4: NG125L,
- 5: 10-16 A,
- 6: 20-25 A,
- 7: 32-40 A,
- 8: 50-63 A,
- 9: 80-100-125 A.

Circuit-breakers: 1P (240 V) - 2P / 3P / 4P (415 V)
Thermal stress

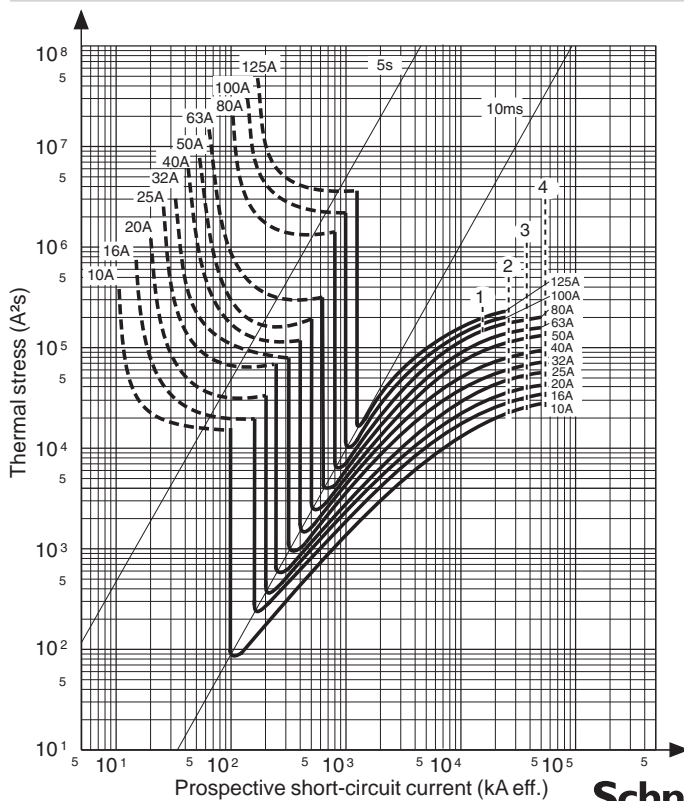

■ Circuit breaker type in accordance with the mark:

- 1: NG125a 80-100-125 A,
- 2: NG125N,
- 3: NG125H,
- 4: NG125L.

Short-circuit current limiting (cont.)

Limitation curves for 525 V network

NG125a, N, H, L curve C

2P / 3P / 4P circuit-breakers

Peak current

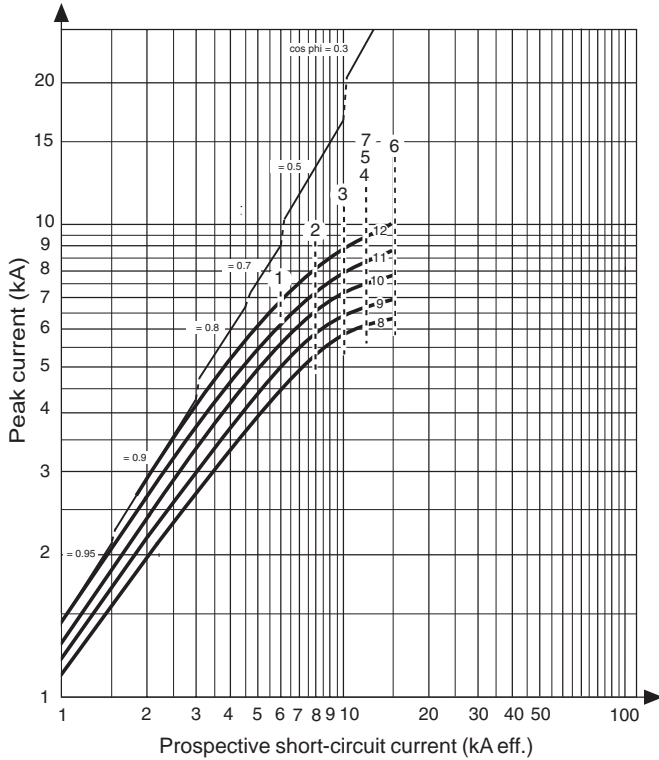

■ Circuit breaker type in accordance with the mark:

- 1: NG125a 3, 4P,
- 2: NG125N 2, 3, 4P,
- 3: NG125H 3, 4P,
- 4-5: NG125H 2P/NG125L 3, 4P,
- 6: NG125L 2P,
- 7: NG125 LMA 2, 3, 4P.

2P / 3P / 4P circuit-breakers

Thermal stress

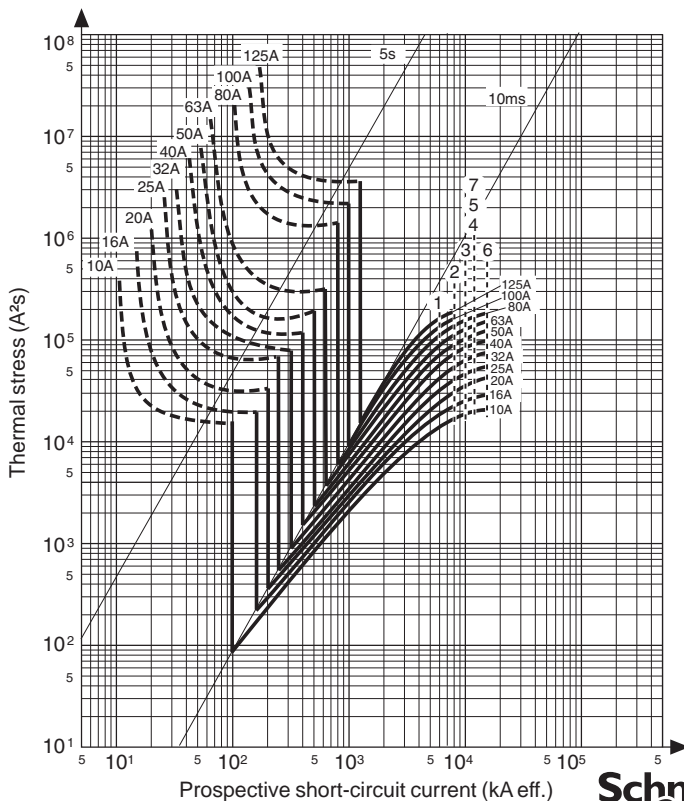

■ Circuit breaker type in accordance with the mark:

- 1: NG125a 3, 4P,
- 2: NG125N 2, 3, 4P,
- 3: NG125H 3, 4P,
- 4-5: NG125H 2P/NG125L 3, 4P,
- 6: NG125L 2P,
- 7: NG125LMA 2, 3, 4P.

Schneider Electric Singapore Pte Ltd (Co. Reg. No.: 197903476G)

10 Ang Mo Kio Street 65
#02-17/20 TechPoint
Singapore 569059
Tel: +65 6480 2001
Fax: +65 6484 7800
Email: customer-care.sg@schneider-electric.com
Website: www.schneider-electric.com.sg

Brunei Office
Unit No. 11, 1st Floor Bangunan Desa Delima
Lot 6418, Simpang 44
Kg Pancha Delima BB 4513
Jalan Muara, Negara Brunei Darussalam
Tel: +673 233 2490
Fax: +673 233 2491

As standards, specifications and designs change from time to time,
please ask for confirmation of the information given in this publication.

www.fengshengelectric.com.sg

SESG 201203001